

## Development of Collective Thomson Scattering System Using the Gyrotrons of Sub-Tera Hz Region

Y. Tatematsu 1), S. Kubo 2), M. Nishiura 2), K. Tanaka 2), N. Tamura 3), T. Shimozuma 2), T. Saito 1), T. Notake 4), Y. Yoshimura 2), H. Igami 2), H. Takahashi 2), T. Mutoh 2), K. Kawahata 2), K.Y.Watanabe 2), Y. Nagayama 2), Y. Takeiri 2), K. Ida 2), H. Yamada 2), O. Kaneko 2), A. Komori 2) and LHD Experiment Group 2)

1) Research Center for Development of Far-Infrared Region, Univ. of Fukui, 3-9-1 Bunkyo, Fukui, 910-8507, Japan

2) National Institute for Fusion Science, 322-6 Oroshi cho, Toki, 509-5292, Japan

3) Dept. of Energy Science and Technology, Nagoya Univ., Nagoya, 464-8463, Japan

4) Tera-Photonics Laboratory, RIKEN, 519-1399, Aramaki Aza Aoba, Aoba-ku, Sendai, 980-0845, Japan

E-mail contact of main author: [tatema@fir.u-fukui.ac.jp](mailto:tatema@fir.u-fukui.ac.jp)

**Abstract.** Collective Thomson scattering (CTS) system is being developed for fusion plasma and CTS measurement on the large helical device (LHD) plasma is discussed. Sub-terahertz frequencies are suitable to the probe beam for CTS on LHD. According to the feasibility study, frequency around 0.4 THz is best for the CTS measurement on LHD high density plasma, and power of 100 kW is required. Thus, only gyrotrons in the sub-terahertz range can meet these parameters. At the first stage of development, second harmonic gyrotrons have been developed. A sealed-off type of gyrotrons has been manufactured to improve a demountable one. Measured output power has increased to about 60 kW. In parallel with the development of gyrotrons, an actual CTS system using a 77 GHz gyrotron originally installed for heating is being developed as a benchmark of LHD CTS. A heterodyne receiver system of a fundamental mixer with a fixed frequency local oscillator was installed on the upstream of the transmission line. The probe beam is 100% power modulated at 50 Hz to separate the scattering component from background ECE. Signals that can be attributed to the CTS were obtained and the analysis method of these data is developed.

### 1. Introduction

Collective Thomson scattering (CTS) is a unique and the most promising method to measure the ion velocity distribution function that is key information in the reactor grade plasma. Recent developments of the high power gyrotron in the sub-terahertz region enabled us to envisage its application to CTS in the fusion relevant plasmas as those in ITER[1]. For a power source of CTS, fusion grade gyrotrons with frequencies from tens of GHz to 140 GHz are considered and experiments with these gyrotrons have started[2]. However, electromagnetic waves with these frequencies suffer from a strong plasma dispersion effect when they are applied to high density plasma. Moreover, high level background electron cyclotron emission (ECE) is a large noise source. Use of a sub-terahertz gyrotron will resolve these problems. We have started development of CTS by using these sub-terahertz gyrotrons for application to the large helical device (LHD) and also started development of high power gyrotrons with this frequency range. For the first stage of the development, we have fabricated a pulse gyrotron operating around 400 GHz frequency range at second harmonic using an 8 T-superconducting magnet[1,3-5]. A target power of the gyrotron is 50 kW. With this gyrotron experiments, measurement methods for frequency in sub-terahertz range and for low average output power in short pulse operations have been established. For actual application to CTS, since it is difficult to obtain stable and high enough output power with second harmonic gyrotrons, development of fundamental ones will be required, which are

able to radiate power more easily, more strongly and more stably than second harmonic ones. Therefore, we have started design of a fundamental gyrotron with a 15 T magnet.

In parallel with the development of the sub-terahertz source, it is important to obtain know-how of operation of a CTS system on a fusion plasma device and to develop the method of receiving and analyzing the CTS signal. One of the 1MW, 77 GHz gyrotrons for electron heating and transmission/antenna system for that in LHD are selected as the probing source and probing/receiving system for the benchmark test. Well defined Gaussian beam originally designed for localized heating is also suitable for receiving the scattered power from a definite scattering volume. A heterodyne receiver system is installed on the other end of the transmission line[6]. After executing the receiver gain adjustments and calibration of each channel, clear CTS spectra for NB heated plasma have been obtained. These data give us confidences that ECRH system in LHD works also well as CTS system and can be a good benchmark for the CTS using sub-THz gyrotron.

## 2. Feasibility Study of CTS

In advance of sub-terahertz gyrotron development, the condition of CTS was examined. CTS in this frequency range has many advantages. First, FIG. 1 indicates  $\alpha = 1$  lines for various plasma density  $n_e$  on the frequency-scattering angle plane, where  $\alpha$  is the Salpeter parameter defined as  $1/k\lambda_D$ . Here,  $k$  is the wave number of fluctuation wave and  $\lambda_D$  is Debye length. As shown in FIG.1, the CTS condition ( $\alpha > 1$ ) for the probe beam in the sub-terahertz frequency range is satisfied for large scattering angle larger than 90 degrees in the fusion grade plasma. This provides good spatial resolution. Second, the sub-terahertz wave does not suffer from refraction due to cutoff in plasma of the order of  $10^{20} \text{ m}^{-3}$ . Third, it is almost free from cyclotron absorption since its frequency is much higher than harmonics of the cyclotron frequency. Forth, then, the background ECE will be at a very low level.

Two available ports on the LHD vacuum vessel are tentatively chosen for installation of injection and receiving antennas. For this choice, scattering angle  $\theta_s$  is 104 degrees, which is large enough to obtain high spatial resolution. Beam radius is calculated assuming a Gaussian beam. When the beam radius is focused to  $w_0 = 1 \text{ cm}$  at the

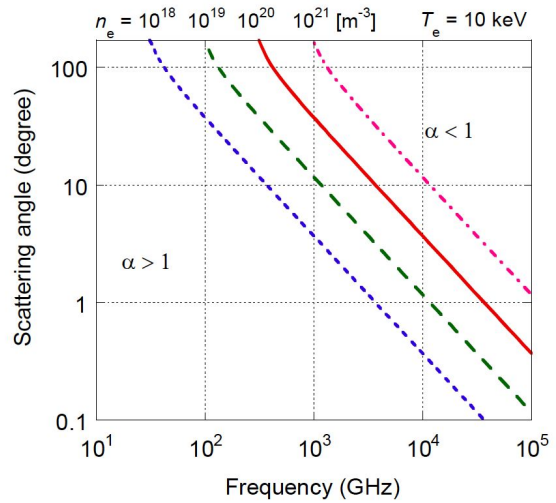

FIG.1. Salpeter parameter  $\alpha = 1$  lines on the frequency-scattering angle plane for  $T_e = 10 \text{ keV}$ . CTS condition is  $\alpha > 1$ .

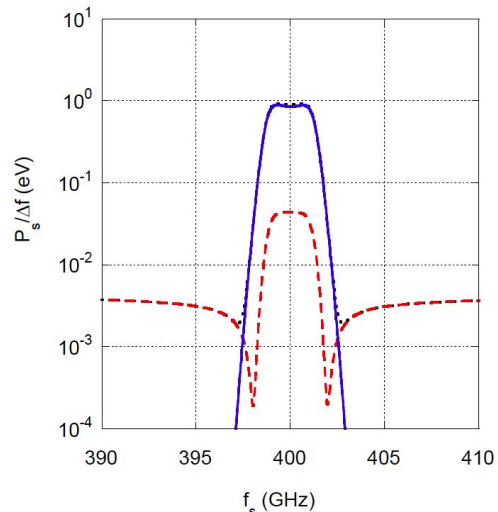

FIG.2. Scattering power spectrum in unit band frequency for  $T_e = T_i = 2 \text{ keV}$ ,  $n_e = 10^{20} \text{ m}^{-3}$ . Solid and dashed lines indicate power spectra due to motions of electrons collective and non collective with ions, respectively.

scattering point, the radius  $w_i$  at the injection port is 5 cm for 0.4 THz. This value is small enough that the antenna can be installed without difficulty. Next, ray tracing calculations confirmed that a probe beam with frequency of 0.4 THz propagates through plasma of the peak electron density of  $10^{20} \text{ m}^{-3}$  and reaches the center of plasma without refraction.

Scattering power spectrum observed at the receiving antenna is evaluated as

$$P_s = P_{in} n_e r_e^2 \Gamma S \Delta f \frac{\lambda_i^2}{\sqrt{\pi w_0 \sin \theta_s}}, \quad (1)$$

where  $P_{in}$  is the gyrotron power,  $n_e$  is the electron density,  $r_e$  is the classical electron radius,  $\lambda_i$  is the wavelength of the incident wave,  $\Delta f$  is the detection band width,  $\Gamma$  is the geometrical factor and  $S$  is the scattering form factor[7]. An example of power spectrum per unit band frequency is show in FIG. 2, where  $P_{in} = 100 \text{ kW}$ ,  $n_e = 10^{20} \text{ m}^{-3}$ ,  $w_0 = 1 \text{ cm}$  and temperatures  $T_e = T_i = 2 \text{ keV}$  are assumed. Solid and dashed lines plot the power spectra stemming from electron motion collective with ions and thermal electron motion, respectively. Collective scattering is dominant and the spectrum of  $P_s$  is able to give us ion information. The calculated power from the collective motion with bulk ions per unit frequency band is in the range of 0.1 - 1 eV. The background ECE level calculated with a radiation transfer code is less than 0.1 eV for the peak electron temperature of 2 keV[3]. With the pulse width of 100  $\mu\text{s}$  and 100 MHz detection band width, a signal to noise ratio of the order of 10 is expected for the 2.75 T standard operation of LHD. Thus, 0.4 THz, 100 kW gyrotron is one of promising candidates of power source for measurement of the bulk ion velocity distribution with CTS from high density plasma in LHD.

### 3. Development of Sub-Terahertz Gyrotrons

Taking account of the background ECE level, an output power of 100 kW would be required for the CTS from high density plasma of the order of  $10^{20} \text{ m}^{-3}$ . At the first stage of development, we have fabricated a pulse gyrotron operating in the 400 GHz frequency range at second harmonic using an 8T-superconducting magnet. The cavity dimension is 2.99 mm in radius and 12 mm in length of the straight section. This gyrotron was constructed as a demountable type.

Experimental results obtained with this gyrotron have been reported in Refs. [1,3-5]. Oscillation power was measured with a carefully designed water load for measurement of a low average power. The water load was set just outside the vacuum window. This gyrotron has no internal mode convertor and the oscillation power is transmitted to the vacuum window through a straight section with an up taper. The normal pulse width for power measurement is 1  $\mu\text{s}$  and the repetition frequency is 10 Hz. The beam voltage was set at around 57 kV. The maximum power obtained is about 50 kW for  $\text{TE}_{6,5}$  mode (349 GHz) and about 40 kW for  $\text{TE}_{8,5}$  mode (390 GHz)[1]. These values are new records of gyrotron power in this frequency range at second harmonic resonance.

In the experiments of the first stage gyrotron, some problems appeared such as accuracy of gyrotron assembly, good vacuum condition in the gyrotron tube, precise tuning of the electron beam radius in the cavity, operation at high voltage to keep good quality of the electron beam, etc. Therefore, as the second stage, we have fabricated a sealed-off gyrotron for precise assembly and good vacuum condition. The shape of insulating ceramics of the electron gun has been also changed to suppress discharge on the surface of the atmosphere side. The electro-dynamical design as a magnetron injection gun is the same as that of the demountable

type gyrotron. The same group of the oscillation modes as that of the demountable type gyrotron was chosen. The cavity dimension is the same as that of the first gyrotron. Oscillation is in the pulse mode. The pulse width is several microsecond and the repetition rate is several hertz to over ten hertz.

Several oscillation peaks were observed in the range of the magnetic field strength  $B$  at the cavity corresponding to 400 GHz band oscillation. To confirm second harmonic oscillations, they were measured through a high pass filter with cut off frequency of 303 GHz. Moreover, frequency measurement with a Fabry-Perot interferometer and with a harmonic mixer identified oscillation mode of each peak. The peak around 6.8 T is the  $TE_{6,5}$  mode. For the peaks in the region from 7.4 T to 7.8 T,  $TE_{3,7}$ ,  $TE_{1,8}$ ,  $TE_{17,2}$  and  $TE_{8,5}$  modes have been identified in this sequence with increasing  $B$ . A fundamental  $TE_{4,3}$  mode is often observed with the  $TE_{8,5}$  mode simultaneously. Single mode oscillation of  $TE_{8,5}$  mode was obtained on the first demountable type gyrotron, however, it was not obtained on the second new one. The reason of this difference is not sure. One of probable reasons is reflection off the vacuum window, which strongly affects the property of mode excitation in the cavity[8].

For the single second harmonic mode oscillation peak, output power was measured with a water load. It has been corrected considering the heat capacity and reflection coefficient of the container used in water load. In FIG. 3 output power of the second harmonic oscillations is plotted against the beam current  $I_b$  for  $V_k = 60$  kV. Power of the  $TE_{1,8}$  mode is dominant. However, low power simultaneous oscillation of the  $TE_{17,2}$  mode cannot be fully excluded. The maximum power of 56 kW is obtained around  $I_b = 9$  A. FIG. 4 is the power-frequency plot obtained with second harmonic gyrotrons. The new data obtained with the sealed-off type gyrotron is added to FIG. 7 in Ref. [1].

With the second harmonic operation, we have treated 400 GHz frequency electromagnetic wave and established measurement methods of this frequency range and low average power. Although high power single mode sub-terahertz oscillation at second harmonic has been successfully demonstrated, further higher power and stable oscillation are necessary for real application to CTS measurements. For this purpose, fundamental operating gyrotron is more suitable. Cavity design of a fundamental gyrotron operating around 400 GHz frequency was started. A preliminary calculation shows that

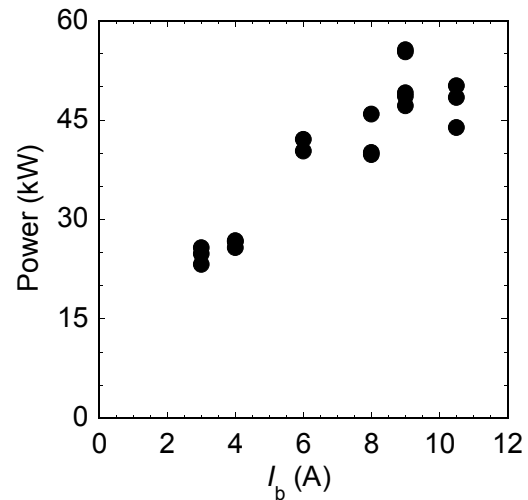

FIG.3. Measured output power of second harmonic oscillations against  $I_b$  for  $V_k = 60$  kV

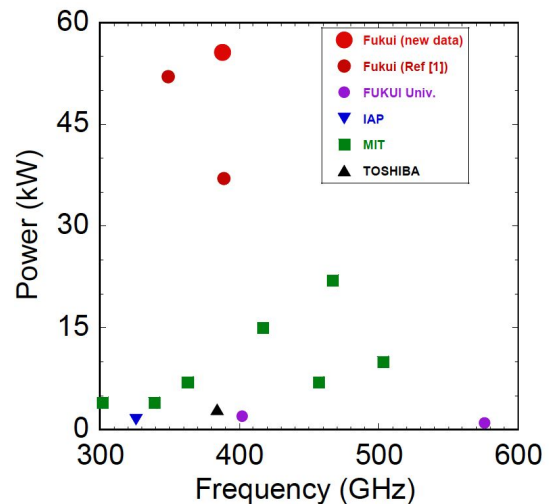

FIG.4. Development status of second harmonic gyrotrons in the radiation power and frequency space. Data with various pulse widths are contained. The biggest circle denotes the data obtained by the new sealed-off type gyrotron.

an output power of more than 200 kW can be expected for practical parameters of  $V_k = 65$  kV and  $I_b = 10$  A.

#### 4. CTS Measurement System Using a 77 GHz Gyrotron in LHD

The large helical device (LHD) is the stellarator/heliotron plasma confinement machine equipped with several plasma heating systems. The investigations of the ion dynamics in the velocity space is of much importance. CTS has a potential to supply a direct information of the ion velocity distribution function[2,9]. Furthermore, high power electron cyclotron resonance heating (ECRH) system has been installed on the LHD that can be utilized for CTS. Eight gyrotrons are in operation in the LHD[10] and eight corrugated transmission lines (6-88.9 id and 2-31.75 mm id) are connected to the LHD. Two sets of injection antenna are installed on 4-LHD ports (5.5U, 9.5U, 2-O and 1.5L) .

One upper port (9.5U) antenna set is selected as a CTS probe and receiving antenna where one of the powerful 77 GHz gyrotrons that achieved more than 1 MW over 5 s is connected[11]. This gyrotron has a triode gun that allows high frequency power modulation without degrading the oscillating mode which is one of the important features for the CTS.

This antenna set includes another Gaussian beam mirror suitable for receiving the scattered power from a definite scattering volume. The probing and receiving beam features and controllability are well documented by the high power beam profile measurement on the target screen placed on the mid-plane of the LHD as shown in FIG. 5. The temperature rise of the screen is recorded by an IR camera.

A receiver system is installed on the upstream of the transmission line, which is normally used for high power transmission for ECRH. A waveguide switch is attached on the 88.9 mm id corrugated waveguide transmission system so that the injection transmission line is used for receiving.

A block diagram of the receiver is shown in FIG. 6. The receiver consists of a highly sensitive heterodyne radiometer with multi-channel filter bank. At the front end, two multi-stage notch filters with the 3 dB band width of 300 MHz and total attenuation of -120 dB at the center probing frequency, 76.95 GHz, are placed to avoid the high level stray radiation that can

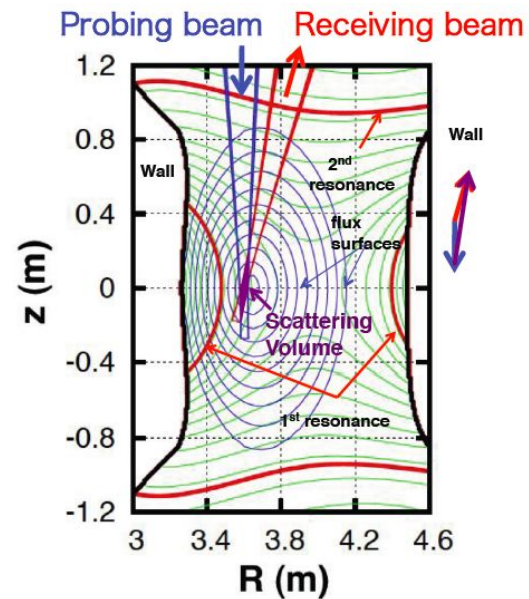

FIG.5. Poloidal cross section of the LHD and probing, receiving beam for CTS. Here the fundamental and the second harmonic resonance layers for 77 GHz are shown with red lines for the case of magnetic field setting of 2.4 T.

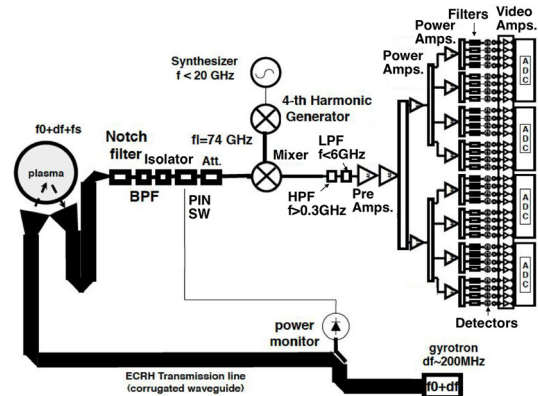

FIG.6. A Block diagram of the 32 channel receiver system for CTS.



damage the mixer or make ghost signal at the mixer and make saturation of the intermediate frequency (IF) amplifier. A pin-switch is also inserted to block the spurious mode which is excited at the turn on or off of the gyrotron out of the notched but sensitive frequency, although this pin-switch was kept open in the experiment described here since the actual level of this spurious signal does not degrade the spectrum. A band pass filter from 72 to 82 GHz to filter out the lower side band of the mixer of the local frequency at 74 GHz is placed in front of the mixer. IF from 300 MHz to 6 GHz at the upper side band of the mixer is amplified by a low noise amplifier and divided to a filter bank. Since the gyrotron oscillating frequency can be subject to a shift of the order of 100 MHz during the oscillation or at the ramping up phase of the anode voltage, an IF center frequency tracking system using a harmonic mixer will be also attached for the precise estimation of the bulk component. The filter bank consists of 32 filters followed by rectifiers and video amplifiers. The frequency characteristics of all these components are measured by vector network analyzers (VNA). The amplifier gain of each channel is adjusted to avoid gain compression, and to stay in the linear regime.

Relative sensitivities of the receiver channels are calibrated by chopping the liquid nitrogen and room temperature absorbers placed in front of the opened transmission waveguide that is so to say "hot and cold" method.

Due to the uncertainty of the coupling factors of the radiation inside of the LHD vacuum vessel to the waveguide through the antenna system or that of "hot and cold" source to the waveguide, the calibration so far is relative.

The linearity of each output signal is checked and the relative amplification of each channel is adjusted by sending the level controlled swept output from the synthesizer in the IF frequency range that simulates the mixer output so that the output signal levels are within linear regime in the actual experimental condition.

In FIG. 7 are shown the time evolutions of the NBI heated discharge in the LHD when the CTS data are acquired. The magnetic field was set at 2.4 Tesla to reduce the background ECE for CTS. The geometrical relation between the probing, receiving beams, fundamental, second resonance layer and plasma are as shown in FIG. 5. The measuring scattering

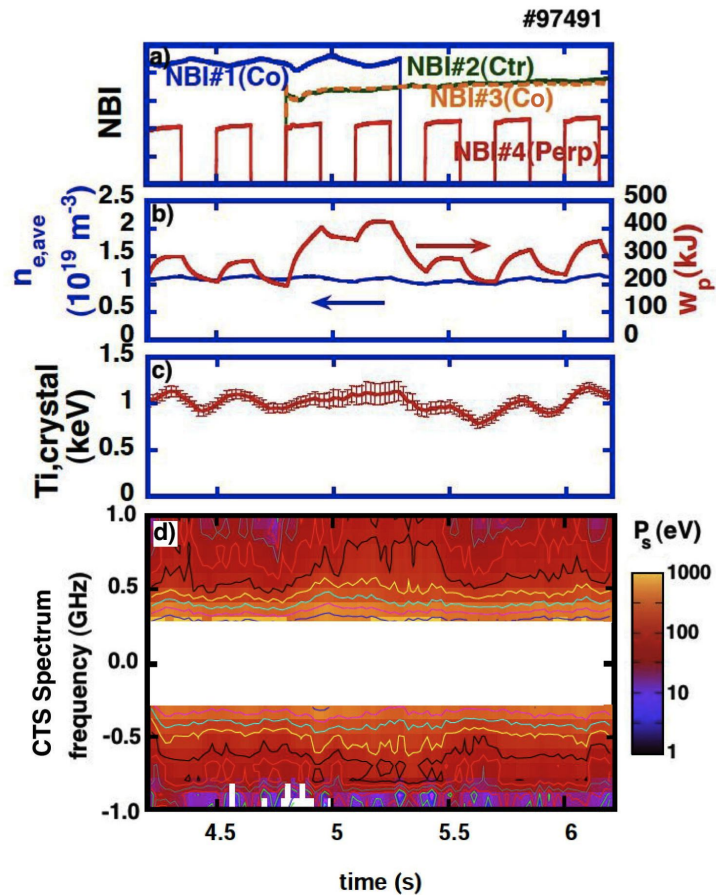

FIG. 7. Time evolution of the discharge of the a) NBI#1 and #3 Co-beam, NBI#2 Ctr-beam and NBI#4 perpendicular beam heated plasma. b) Stored energy and averaged electron density and c) Ion temperature estimated from crystal spectroscopy. d) Deduced power spectrum shown as logarithmic contour plot. center channels near the gyrotron frequency are blocked by the notch filter.

wavevector points upwards and has an angle 80.8 degree to the magnetic field. This angle is in the range where the scattering spectrum is barely free from the effect of the lower hybrid resonance as discussed in Refs. [12,13].

Three tangential negative ion based neutral beams (NNB) with the energy of 180 keV are injected in co- and counter- direction which are used to produce and sustain the plasma. Here, #1 and #3 are injected to the co- and #2 is to the counter direction. In addition to the tangential NNB, 100 ms pulse perpendicular positive ion based neutral beam (PNB) with the energy of 40 keV is injected with the interval of 200 ms repetitively as shown in FIG. 7a). CTS probing gyrotron power is turned on from  $t = 4.2$  to 6.2 s with 100% power modulation. Macroscopic plasma parameters are not affected by the probing gyrotron beam, since the probing beams do not directly intersect with the fundamental EC resonance as shown in FIG. 5, but microscopic parameters such as local electron temperature can be affected by the heating due to the multi-reflection of the probing beam. Actually, the raw CTS signals show a small sinusoidal component synchronous with the modulation of the probing beam. Such a heating component of the background ECE can well be separated from the scattering component by the method described in Ref. [14]. These beams do intersect with the second harmonic EC resonance at far away from the plasma confinement region and cannot contribute to either the heating or the background ECE.

In response to the NBI, stored energy changes, but the averaged electron density is almost kept constant at  $1 \cdot 10^{19} \text{ m}^{-3}$  as shown in FIG. 7b). FIG. 7c) is the indication of the bulk ion temperature deduced from the Doppler broadening of the Ar line by the crystal spectroscopy. Due to the high beam energy, 180 keV, of the tangential NB and due to relatively low density operation, the bulk ion temperature shows small change to the tangential NBI. The bulk ion temperature responds well to the perpendicular NBI and changes from 0.8 to 1 keV. The time evolution of the CTS spectra analyzed at each probing beam modulation discussed in Ref. [14] is shown as a contour plot in FIG. 7d). Due to the high rejection of the notch filter near the gyrotron frequency, sensitive channels available for the spectrum analysis lie in the range of a few to a few tens of keV proton velocity. Calculated spectra using the observed electron temperature,  $T_e = 0.82 \text{ keV}$ , with input parameter  $T_i \sim 0.7 \text{ keV}$ , with and without slowing down distribution of 40 keV NBI well fits the measured spectra. Since the resolved scattering wavevector is about 80 degrees to the magnetic field, the CTS spectrum should be sensitive to the change in the ion perpendicular distribution function. The deduced spectra show the tendency that the bulk ion component change is small but the spectral part where the contribution of the 40 keV slowing down distribution dominates changes as expected, although these changes are barely in the error bar.

## 5. Summary

Sub-terahertz, high power gyrotron of the frequency range of 300 to 400 GHz is developed for the probing beam source of the CTS in high density plasma in the LHD. Preliminary investigation indicates that the required power level is 100 kW. As a first stage, demountable and sealed-off second harmonic gyrotrons have been developed and confirmed to achieve almost 60 kW at the frequency near 400 GHz. In order to achieve more powerful and stable oscillation, design study of fundamental gyrotron at 400 GHz has been started.

To accumulate know how of the CTS using high power gyrotron, the ECRH system is utilized in the LHD. The 32-channel CTS receiver system is connected to one of the ECRH transmission/antenna. A one megawatt output 77 GHz gyrotron and its transmission/antenna

system are used as a probing beam. A method to separate CTS component from high ECE background is developed during high frequency probing power modulation. This method is applied to the NB heated plasma and show that deduced CTS spectra behave as expected from classical process of slowing down of high energy ions. These methods of receiver design, CTS spectrum analysis are directly applicable to the sub-terahertz region.

- [1] NOTAKE, T. et al., “Development of a Novel High Power Sub-THz Second Harmonic Gyrotron”, *Phys. Rev. Lett.* **103** (2009) 225002.
- [2] BINDSLEV, H. et al., “Fast-Ion Dynamics in the TEXTOR Tokamak Measured by Collective Thomson Scattering”, *Phys. Rev. Lett.* **97** (2006) 205005.
- [3] NOTAKE, T. et al., “Subterahertz gyrotron developments for collective Thomson scattering in LHD”, *Rev. Sci. Instrum.* **79** (2008) 10E732.
- [4] SAITO, T. et al., “Generation of high power sub terahertz radiation from a gyrotron at second harmonic resonance”, *Conference Digest of 34th International Conference on Infrared, Millimeter, and Terahertz Waves* (2009) R4D05.
- [5] SAITO, T. et al., “Development of terahertz gyrotrons and their application to LHD CTS”, *J. Phys.: Conference Series* **227** (2010) 012013.
- [6] KUBO, S. et al., “Collective Thomson scattering study using gyrotrons in LHD”, *Plasma and Fusion Research* **5** (2010) S1038.
- [7] SHEFFIELD, J. “Plasma Scattering of Electro-magnetic Radiation”, Academic Press, New York, 1975.
- [8] DUMBRAJS, O. et al., “Reflections in gyrotrons with axial output”, *IEEE Trans. Plasma Sci.* **32** (2004) 899.
- [9] MEO, F. et al., “Design of the collective Thomson scattering diagnostic for International Thermonuclear Experimental Reactor at the 60 GHz frequency range”, *Rev. Sci. Instrum.* **75** (2004) 3585.
- [10] KUBO, S. et al., “Profile Control by local ECRH in LHD”, *Proc. 22nd IAEA Fusion Energy Conference*, Geneva, Switzerland. 13-18 October 2008.
- [11] TAKAHASHI, H. et al., “The Development of a 77-GHz, 1-MW ECRH System for the Large Helical Device”, *Fusion Sci. Technol.* **57** (2010) 19.
- [12] NISHIURA, M. et al., “Design of collective Thomson scattering system using 77 GHz gyrotron for bulk and tail ion diagnostics in the large helical device”, *Rev. Sci. Instrum.* **79** (2008) 10E731.
- [13] SUVOROV, E.V. et al., “Ion temperature and beam-driven plasma waves from collective scattering of gyrotron radiation in W7-AS” *Plasma Phys. Control. Fusion* **37** (1995) 1207.
- [14] KUBO, S. et al., “Collective Thomson Scattering Study using Gyrotron in LHD”, *Contrib. to Plasma Phys.* **50** (2010) 624.