

§18. Study of SMES System Using Dry Type Superconducting Coil Designed to Protect from Momentary Voltage Drop

Chikaraishi, H., Mito, T., Baba, T., Sumiyoshi, F., Kawagoe, A. (Kagoshima Univ.), Iwakuma, M. (Kyushu Univ.), Okumura, K., Kuge, A. (Technova Co., Ltd.), Abe, R. (Shibuya Kogyo Co., Ltd.)

Many precision industrial facilities such as an electronic device facility, display panel or imaging device are on the stage in the world. To protect the whole facility, larger capacity UPS is required. As an energy storage device for UPS, we consider the maximum power and stored energy and we select a superconducting magnet.

Figure 1 shows a diagram of proposed SMES UPS. The coils, inverters and converters are separated in 1MJ, 500kW and 700kW modules to reduce the construction cost as shown in the figure. The exciter in the figure is used to keep coil current constant while the utility grid is in operation. This exciter used in this system is a generic switching dc power supply consists of IGBT inverter, step down transformer and diode rectifier as shown in Figure 2. While the utility grid is in operation, the IGBT in the chopper turns on to make current path and the inverter is shut down to make small loss. Under this state, the coil current paths on the solid line shown in Figure 2 (a). When the voltage of the utility grid fail, the exciter automatically shut down and the coil current transfers to the bypass diode D4 as show in Figure 2b. For this operation, the sequence programmed in the controller does not have to take care of the exciter.

After the operation test of 100kJ subscale system, we built a full-scale demo system. This demo system is just half part of the 1MJ SMES shown in figure 1 and Figure 3 shows the circuit diagram. The inverter consists of three arm modules and the chopper consists of two modules in parallel to satisfy the rated coil current of 1 kA. The demo SMES is controlled by DSP controller using Texas TMS320VC33. In this controller, the voltage drop detector, sequence control of the SMES, PWM pattern generator of inverter and chopper, dc link voltage regulator are installed.

Table 1: Specifications of an arm module for full-scale SMES system

Switching device and frequency	IGBT,10kHz
DC link voltage	850 V
Current	560 A

References

- Mito T., et.al., "Development of UPS-SMES as a protection from momentary voltage drop", IEEE Trans. on Applied Superconductivity, Vol 14, June 2004, Pages:721 - 726
- Chikaraishi H., et.,al., "UPS SMES using dry type superconducting coil designed to protect from momentary

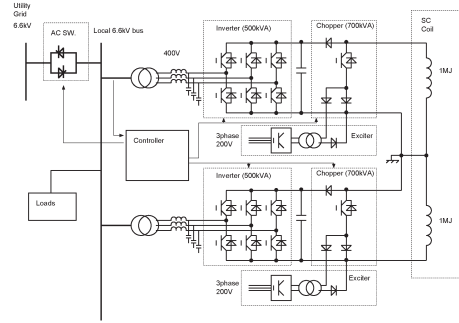

Figure 1: Circuit diagram of 1 MJ class SMES UPS.



(a) Current flow while utility grid is in operation (b) Current flow when utility grid is down

Figure 2: Current flow around exciter used in SMES UPS.

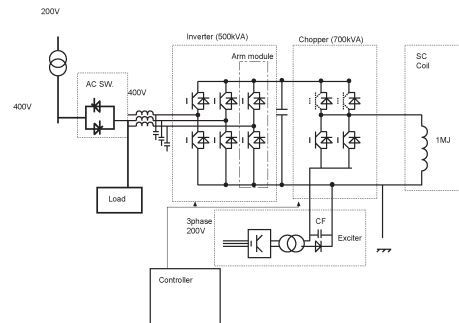

Figure 3: Circuit diagram of full-scale demo SMES.

voltage drop", Power Electronics and Applications, 2005 European Conference on 11-14 Sept. 2005 Page(s):7 pp. 3. Mito T., et.al., "Validation of the High Performance Conduction-Cooled Prototype LTS Pulse Coil for UPS-SMES", IEEE Trans. on Applied Superconductivity, Vol 16, June 2006, Pages:608 - 611