

§56. Probe Measurement under the Influence of Fast Electron in QUEST Boundary Plasma

Tsushima, A., Tawaraya, T. (Yokohama Na. Univ.),
Sakamoto, M. (Univ. Tsukuba),
Ishiguro, M., Hanada, K. (Kyushu Univ.)

To measure the boundary plasma of a spherical tokamak QUEST, a probe head, as shown in Fig. 1, was attached at the top of a fast scanning system and moved back and forth in a distance of about 500 mm horizontally during about 1 s. On the probe head, there were five cylindrical electrodes with diameters of 1 mm and lengths of 2 mm: three electrodes (1, 2, 3) were set in array on an insulator mound and two electrodes (A, B) were set aside and paired for a Mach probe. One of the three electrodes (3) in array on the insulator mound was made of molybdenum, the other four electrodes (1, 2, A, B) were made of tungsten.

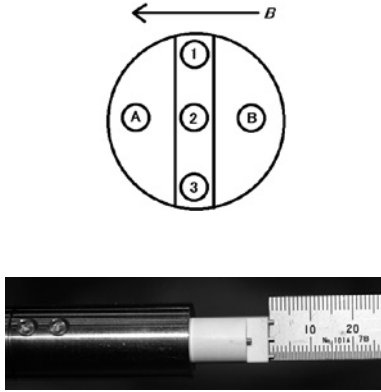

Fig. 1: Top view and side view of probe head with five cylindrical electrodes: three electrodes (1, 2, 3) were set in array on an insulator mound and two electrodes (A, B) were set aside; Four electrodes (1, 2, A, B) were made of tungsten and one electrode (3) was made of molybdenum.

Since the effective coefficient of secondary electron emission by electron impact depends on a material, we expect that the difference between the probe signal from the tungsten electrode and that from the molybdenum electrode indicates the effect of secondary electron emission. Then, using the tungsten and molybdenum electrodes (2 and 3) on the insulator mound, probe characteristics were obtained in a boundary plasma at a limiter shadow. Relations between $\ln I_e$ and V_p are shown in Fig. 2 by dots. The top and bottom figures are the results using the tungsten and molybdenum electrodes, respectively. Here, I_e is electron current and V_p is bias applied to each electrode. Slopes of solid lines indicate electron temperatures T_{ef} of fast electron components, $T_{ef} = 26$ eV and $T_{ef} = 24$ eV for the tungsten and

molybdenum electrodes, respectively; and those of broken curves indicate electron temperatures T_{es} of slow electron components, $T_{es} = 8.7$ eV and $T_{es} = 7.4$ eV for the tungsten and molybdenum electrodes, respectively. The corresponding electron temperatures for the two electrodes almost agree with each other, and density ratios between fast and slow electron components, (n_{ef}/n_{es}) 's, from the two electrodes agree with each other, if the reduction of the electron current by $1 - \bar{\delta}(T_e)$ is assumed. Here, $\bar{\delta}(T_e)$ is the effective coefficient of secondary electron emission due to a Maxwellian electron with an temperature T_e and is represented by

$$\bar{\delta}(T_e) = \delta_m (2.72)^2 \int_0^\infty \xi e^{-\xi - 2\sqrt{(k_B T_e / E_m) \xi}} d\xi \quad (1)$$

with $\delta_m = 1.36$ and $E_m = 650$ eV for the tungsten electrode and $\delta_m = 1.25$ and $E_m = 375$ eV for the molybdenum electrode.¹⁾ These results suggest that the effect of secondary electron emission can be considered using $\bar{\delta}(T_e)$.

We are now evaluating the ion flow velocity of the QUEST boundary plasma with the influence of secondary electron emission.

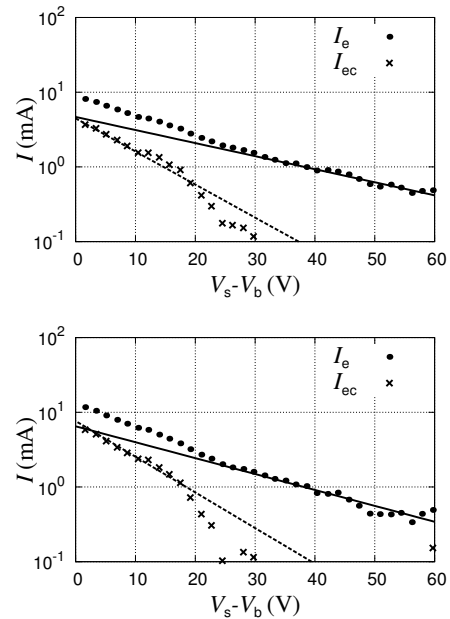

Fig. 2: Semilogarithmic plots of I_e are depicted by dots, where the top and bottom figures are from measurements of tungsten and molybdenum electrodes, respectively. A solid line fits the dots for $V_s - V_b > 30$ V. Crosses are obtained by subtracting the solid line from the dots. A broken line fits the crosses for $V_s - V_b < 20$ V.

1) Tawaraya, T., Tsushima, A., and Yoshimura, S.: *Proc. Plasma Conference 2011* (Kanazawa, Japan, 2011) 22P172-B.