

NATIONAL INSTITUTE FOR FUSION SCIENCE

Hydrogen Absorption Behavior into Boron Films by Glow Discharges in Hydrogen and Helium

K. Tsuzuki, M. Natsir, N. Inoue, A. Sagara, N. Noda, O. Motojima,
T. Mochizuki, T. Hino and T. Yamashina

(Received - July 18, 1996)

NIFS-431

Aug. 1996

RESEARCH REPORT NIFS Series

This report was prepared as a preprint of work performed as a collaboration research of the National Institute for Fusion Science (NIFS) of Japan. This document is intended for information only and for future publication in a journal after some rearrangements of its contents.

Inquiries about copyright and reproduction should be addressed to the Research Information Center, National Institute for Fusion Science, Nagoya 464-01, Japan.

Hydrogen Absorption Behavior into Boron Films by Glow Discharges in Hydrogen and Helium

K. Tsuzuki, M. Natsir, N. Inoue¹, A. Sagara¹, N. Noda¹, O. Motojima¹,
T. Mochizuki², T. Hino², and T. Yamashina²

The Graduate University for Advanced Studies, Oroshi-cho Toki 509-52, Japan

¹National Institute for Fusion Science, Furo-cho Chikusa-ku Nagoya 464-01, Japan

²Department of Nuclear Engineering, Hokkaido University Sapporo 060, Japan

ABSTRACT

Hydrogen absorption behavior into boron films deposited on graphite and stainless steel (SS) has been studied. Hydrogen absorption into an H-depleted boron film was investigated during a hydrogen glow discharge with pressure drop measured by a diaphragm gauge. It was found that, after strong but short time absorption at initial phase, hydrogen atoms were slowly (a few percents of injected H atoms) but continuously absorbed without saturation up to 3 hours, which was not observed with SS liner without boron coating. Hydrogen atoms were not only desorbed but also implanted into the film during a helium glow discharge, and thus, hydrogen atoms were accumulated in the film when H₂ and He discharges were repeated alternately. These accumulation effects enhanced by ions from the glow discharge were investigated quantitatively and the effect of bombarding ion species (H⁺ or He⁺) was discussed. Depth profile of H atoms was measured by elastic recoil detection (ERD). The density of only near surface region was increased when the hydrogen atoms were injected. Longer time exposure to H₂ discharge resulted in increase in surface density and shift of the peak position to deeper into the film. These results were explained by diffusion of H atoms due to ion impact into the films with keeping its saturation level if we consider resolution of ERD method of 25 nm. From the results, applicability of boron film as protection layer of tritium permeation is discussed.

Keywords

boron coating films, hydrogen recycling, hydrogen retention, hydrogen glow discharge, helium glow discharge, thermal desorption

A contributed paper presented in 12th international conference on plasma surface interactions in controlled fusion devices in saint Raphael (France) from May 20 to 24, 1996.

To be published in Journal of Nuclear Materials.

1. INTRODUCTION

Boron film is one of candidate materials for first wall of fusion devices, and has widely been used in many devices [1-6]. It is reported that, at elevated temperature in JT-60U, hydrogen recycling rate is remarkably lower with a boronized wall than with a carbon wall [5]. On the other hand, in CHS (Compact Helical System), it is higher with a boronized wall at room temperature than with a titanium-flashed wall [6]. Since the control of H recycling is important for better plasma control and better plasma confinement [7], especially in future long time discharge [8], precise understanding of H behavior in boron films is important and has been studied using glow discharge in hydrogen and helium.

Hydrogen behavior in boron films on graphite liner has been investigated in NIFS (National Institute for Fusion Science) aiming to apply this technique to LHD (Large Helical Device), where the baking temperature is limited to 100°C [9]. In the previous study, it has been found that the absorption continued for a long time after saturation of near surface [10]. Increase in H retention was observed when H₂ and He discharges were repeated alternately. It is probably because hydrogen or helium ion bombardment have some effects to accumulate H atoms into the boron film. Such phenomena were reported for carbon samples by ion beam impact [11]. Since this problem will be important in future long time discharge especially when tritium is used, we focus our attention on this H accumulation in the films in this work.

The accumulation rate is investigated more quantitatively than previous experiments. The mechanism is discussed with the results of depth profile measurements by elastic recoil detection method.

2. EXPERIMENTAL

An experimental device named SUT (SURface modification Test-stand) is used for this study. Fig.1 shows schematic view of the device. The main chamber is pumped by a turbo molecular pump unit and the base pressure is of 10^{-7} Pa. Boron films are deposited on a cylindrical liner of 400 mm in diameter, 400 mm in height, and 7000 cm² in surface area. The liner is changeable, and a stainless steel (SS) liner is mainly used in this study. The whole liner can be heated up to 500°C by a molybdenum heater with water cooling system to prevent other place to heat.

The experimental procedure consists of three stages; namely (I) film preparation, (II) discharge experiments, and (III) thermal desorption. In the stage (I), boron films are prepared by a DC glow discharge of B₂H₆(5%)+He(95%). The thickness of the boron film is monitored by a quartz oscillator. The coating is continued until the thickness reaches 200 nm (typically 72 min.). Prior to H₂ exposure, the boron film is once heated up to 500°C to evacuate H atoms retained originally in the film during the coating.

In the stage (II), hydrogen and/or helium discharges are carried out to investigate hydrogen absorption and desorption characteristics. Typical discharge parameters are 2.6 Pa, 0.2A, and 400V for hydrogen, and 2.6 Pa, 0.2A, and 250V for helium. The temperature of the liner increased during the discharge because of the power flow from the plasma, but was kept lower than 70°C.

In the stage (III), the liner is heated again to 500°C to measure the retained number of H atoms in the film, and to reset the boron film into the beginning of the stage (II).

After the B-coating (stage (I)), the stage (II) and the stage (III) were repeated alternately with various schemes of the discharge procedure in the stage (II). The procedure in stage (III) is identical through the all series of the experiment. Four series of discharge experiments were performed and described in the next chapter.

Hydrogen pressure during the discharges and the thermal desorptions is measured by a diaphragm gauge and the Quadrupole Mass Spectrometer (QMS) with a differential pumping system calibrated by the diaphragm gauge (see Fig.1). The pumping speed is kept constant during each experiment (15.4 l/s for H₂ and He discharges, and 18.0 l/s for thermal desorption experiments). Absorbed and desorbed number of H atoms is calculated by integrating pressure change multiplied by the pumping speed.

Depth profile of H atoms in the film is measured by Elastic Recoil Detection method(ERD) [12]. Substrates of 10 mm × 20 mm made of SS are placed on a sample holder (see Fig.1) and coated together with the liner in the same condition as the stage (I). The hydrogen atoms retained during the coating is evacuated by a heating up to 500°C together with the liner.

We prepared three samples : H-depleted boron film (experienced only the stage (I)), 1 hour exposure to H₂ discharge, and 3 hours exposure. The samples are once exposed to the air, and set in another chamber for the ERD. Helium ions of 1.5 MeV are generated by AN-2000 Van de Graaff accelerator and injected to the sample at an incident angle of 10° from the sample surface. A solid state detector for ERD is placed at scattered angle of 20°, with a slit and a myler filter of 6 μm thick to cut the scattered He ions. A detector for Rutherford Back Scattering (RBS) is also set at 150° from the beam to investigate He ion fluence and film thickness[12].

3. RESULTS AND DISCUSSION

As a first series in the stage (II), hydrogen discharge of 1 hour was carried out to investigate H absorption. Fig.2a shows hydrogen pressure measured by the diaphragm gauge during the discharge in the case of SS liner with and without boron coating. Strong and short time decrease in H pressure was observed just after the ignition of the discharge. This is understood as hydrogen absorption to H depleted top surface on the liner. The pressure drop was much higher in boronized liner and the maximum absorption flux was almost same as the

ion flux estimated from the discharge current. Total retained H during the 1 hour discharge estimated from the pressure drop was of 2×10^{16} atoms/cm² without B-coating and 11×10^{16} atoms/cm² with coating. The hydrogen absorption capacity was 5 times higher with the boron film than without one. The pressure behavior around the end of the discharge is shown in Fig.2b. In both cases, the pressure once increased and returned to the constant value when the discharge was turned off. It might be release of over saturated H atoms during the discharge. This kind of over saturation has been found in Tokamaks and discussed as "dynamic retention" [13,14]. Similar to the boron film on a graphite liner [10], the pressure in the later half of discharge was lower than those without discharge when the liner was coated with boron film. It means hydrogen atoms were continuously absorbed into the film during 1 hour discharge. In contrast, the pressure during the discharge came back to the initial value before the start of the discharge in the case of SS liner without coating. The continuous absorption was not observed. Thus, we can conclude that hydrogen absorption to boron film has two components : strong and short time absorption, and slow and long time absorption. The slow component was also observed in boron films coated on graphite liner and was not observed SS liner without coating. It means that during slow absorption phase, hydrogen atoms are accumulated in the boron film but not in the liner or their interface.

To confirm this effects, a hydrogen discharge of 3 hours was carried out, as a second series of the stage (II). The increase in H retention was cross-checked by the integration of desorbed H₂ in the stage (III).

The mechanism of this slow absorption is understood as follows. When the energetic ions are injected to the boron film, in which hydrogen is almost saturated, hydrogen atoms trapped in the film is detrapped by the ion impact. Some of the detrapped atoms migrate or are implanted deeper into the film (ion-induced detrapping/implantation). Some of the injected ions are caught by the evacuated trap site and not re-emitted from the surface.

Helium ion bombardment might also cause ion impact detrapping and recoil implantation. Some of the detrapped H atoms migrate to the surface and are desorbed, and the other migrate deeper into the film and contribute to evacuate the near surface H atoms. To investigate this effect, third series in stage (II) was carried out as follows. An hour He discharge was carried out after 1 hour H₂ discharge. Hydrogen atoms of 2×10^{16} atoms/cm² were desorbed. After that, second H₂ discharge was carried out. Strong and short time absorption similar to the first H₂ discharge was observed because hydrogen atoms of near surface were evacuated. The total number of absorbed H during 1 hour was two times larger than desorbed one probably due to the above mentioned migration of H atoms into the film. Thus, retained H is larger than simple 1 hour case (series (1)).

Alternate He/H₂ discharges are carried out one more time in fourth series in stage (II) to investigate the accumulation effect by alternate discharges. The retained number was larger

than that in series (3), which means that hydrogen atoms are continuously absorbed by H or He ion bombardment.

To investigate these effects more quantitatively, the retained number of H in each series is plotted in Fig.3. It was confirmed that the number of absorbed H atoms during discharge (stage (II)) and desorbed one during thermal desorption experiment after that (stage (III)) was almost same in every series. Here, values estimated from thermal desorptions are shown because they contain smaller error than pressure analysis during discharge. During 1 hour discharge (series (1)), hydrogen atoms of 11.0×10^{16} atoms/cm² were absorbed. The number increased to 14.5×10^{16} atoms/cm² in the series (2) by the longer time H₂ exposure. In the series (3), retained H was 13.7×10^{16} atoms/cm². The total discharge time was 3 hours which was same as the series (2). As is mentioned previously, if He ion bombardment has same effect as H₂ ion bombardment to enhance H migration into the film, the retained number should be same in the series (2) and the series (3). The retained number in the series (3) was, however, smaller than that in the series (2). It means that hydrogen ion impact has grater effect to accumulate H atoms into film than He ion impact. In the series (4), total time of H₂ discharge was 3 hours, which was same as the series (2). However, the retained number was clearly larger than the series (2), which means that He discharges have some effect for H accumulation.

To confirm above mentioned model of ion induced detrapping/implantation, depth profile of H atoms was investigated using ERD method. Fig. 4 shows obtained depth profile in the cases of (a) after thermal desorption, (b) 1 hour exposure to H₂ glow, and (c) 3 hours exposure. The density is low and uniform after thermal desorption. In the cases of (b) and (c), the density of near surface region increased. The injected hydrogen atoms are mainly retained in near surface region. When the discharge continued to 3 hours, the peak density increased and the peak position slightly shifted to deeper level compared to the case of 1 hour exposure.

For understanding of these results, we consider resolution of ERD measurements. Relationship between detected depth profile $N_{DET}(x)$ and real profile $N_{REAL}(x)$ can be described as follows with an assumption of gaussian distribution,

$$N_{DET}(x) = \int N_{REAL}(t-x) \bullet g(t) dt$$

where

$$g(t) = \frac{1}{\sigma\sqrt{\pi}} \exp\left(-\frac{t^2}{\sigma^2}\right) : \text{Gaussian distribution function}$$

σ : resolution

x : depth

For simplicity, we assumed real density profile of square type with non-zero background level as is indicated in Fig 4b. The standard profile (A) and resolution σ were determined to obtain best fit to the profile of 1 hour (case (b) in Fig.4a). The saturation level was estimated to be 1.0×10^{22} atoms/cm³. It corresponds to atomic ratio B : H =1 : 1.2, which seems understandable value. We assumed two kinds of square type distribution for the case of 3 hours exposure; (B) density increase (open squares) and (C) depth increase (close squares). A rate of the increase was taken as 30% from the increasing rate of retained H shown in thermal desorption experiments (see Fig. 3). The calculated profiles are indicated in Fig.5. In spite of small difference between (B) and (C), the peak is clearly shifted to the deeper side in (C) compared to (B) and (A). In addition the assumption (C) seems more natural if we assume existence of saturation density. Thus, we can conclude that hydrogen atoms migrate into the film when the film is exposed to H₂ and/or He discharge for long time. It should be noted that the background level in the real profile is much lower than the saturation level. It means that most of the H atoms are desorbed by the heating, which is consistent with the results in gas analysis.

4. A possibility of boron films acting as a protecting layer of tritium penetration

Through present and previous works [10], it has been demonstrated that, independent of substrate materials, most of hydrogen is desorbed from boron films at relatively low surface temperature without leaving hydrogen inside the substrates. This possibility has been shown already in literature [15,16] for small test pieces. In the present work, it is demonstrated for relatively large area around 7000 cm². It is also important that in any of the series (1) - (4), the same amount of hydrogen as absorbed during discharge is re-emitted with a temperature below 500 °C, which was not clearly shown in the experiments with small test pieces. This finding and its confirmation give us an idea to utilize the boron coating as a possible barrier to reduce tritium inventory in spite of large hydrogen absorption at room temperature.

One of the concerns in future reactor is that charge exchange atomic flux of tritium, which has relatively high energy, easily penetrate into plasma-facing surfaces. It causes considerable T inventory and its permeation to cooling channels. Boron films coated through in-situ boronization is porous and a lot of open pores play a role to guide hydrogen isotopes out of the film. Hydrogen isotopes in the pore are presumed to be molecule with low energy and penetration rate to the substrates is expected much smaller than charge-exchange neutral. This structure forces hydrogen stream to the front surface side if the films are maintained at a temperature as high as 400 °C. This is relatively low compared to the required temperature with a carbon surface, which makes the first wall design easier even with a coolant of water. Temperature difference between top surface, where boron films are coated, and coolant can be as small as 400 °C. Thus porous film with hydrogen-desorbing films can act as protection layer of tritium penetration into the substrates.

Although it is necessary to confirm this possibility by additional studies such as an actual investigation on permeation etc. before the final conclusion, the present experiment has shown up this very promising characteristics of boron films.

5. SUMMARY

Hydrogen absorption behavior into boron films was investigated using glow discharge in hydrogen and helium and thermal desorptions. The slow and continuous H absorption into boron films, which had been observed for graphite liner, was also shown for SS liner. Several series of H₂ and/or He discharges were carried out to investigate the rate of H accumulation by the slow absorption quantitatively. The results showed that H₂ and He ions impact cause slow absorption, and hydrogen ions have greater effect than He ions.

Depth profile of H atoms was measured by ERD method. The H density of only near surface region was increased by H implantation. The longer time exposure resulted in increase in the peak density and shift in the peak position to deeper into the film. Simple calculation considering the resolution of the ERD indicates that the results can be explained by the migration of H atoms deeper into the film with keeping its saturation density.

As a problem for application to future reactor, a possibility of boron films acting as a protecting layer is discussed, which prevents tritium to penetrate into the wall and enables tritium desorption easier than other materials.

REFERENCES

- [1] J. Winter et al., J. Nucl. Mater., 162-164 (1989) 713.
- [2] H.F. Dylla et al., J. Nucl. Mater., 176-177 (1990) 337.
- [3] G.L. Jackson et al., J. Nucl. Mater., 196-198 (1992) 236.
- [4] U. Schneider et al. J. Nucl. Mater., 176-177 (1990) 350.
- [5] M. Saidoh et al., Jpn. J. Appl. Phys, 32 (1993) 3276.
- [6] H. Yamada et al., Jpn. J. Appl. Phys., 33 (1994) L1638.
- [7] S. Higashijima et al., J. Nucl. Mater., 220-222 (1995) 375.
- [8] N. Noda, In *Contribution to high-temperature plasma physics*, p 21. Akademie Verlag, Berlin (1994).
- [9] N.Noda, J. Nucl. Mater., 220-222 (1995) 623.
- [10] K. Tsuzuki et al. in print in Vacuum.
- [11] A. A. Haastz and J.W. Davis, J. Nucl. Mater. 209 (1994) 155.
- [12] M.Natsir et al, in print in Vacuum.
- [13] V. Philipps et al. J. Nucl. Mater., 162-164 (1989) 520.

- [14] J. Ehrenberg, J. Nucl. Mater., 162-164 (1989) 713.
- [15] H. Toyoda et al., J. Nucl. Mater. 162-164 (1989) 713.
- [16] T. Hino et al., J. Nucl. Mater., 220-222 (1995) 851.

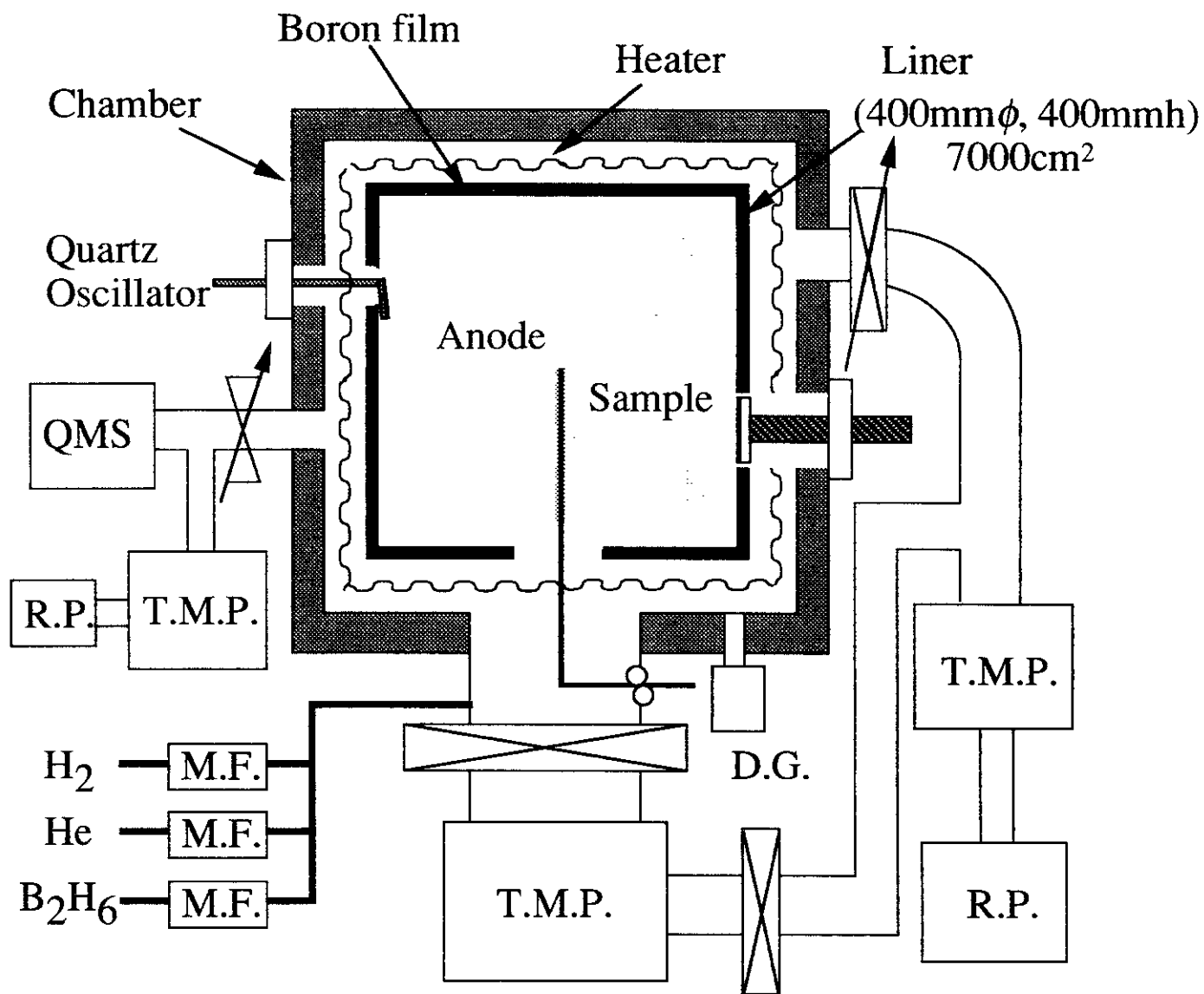

Fig.1. Schematic view of experimental device named SUT(Surface modification Teststand).

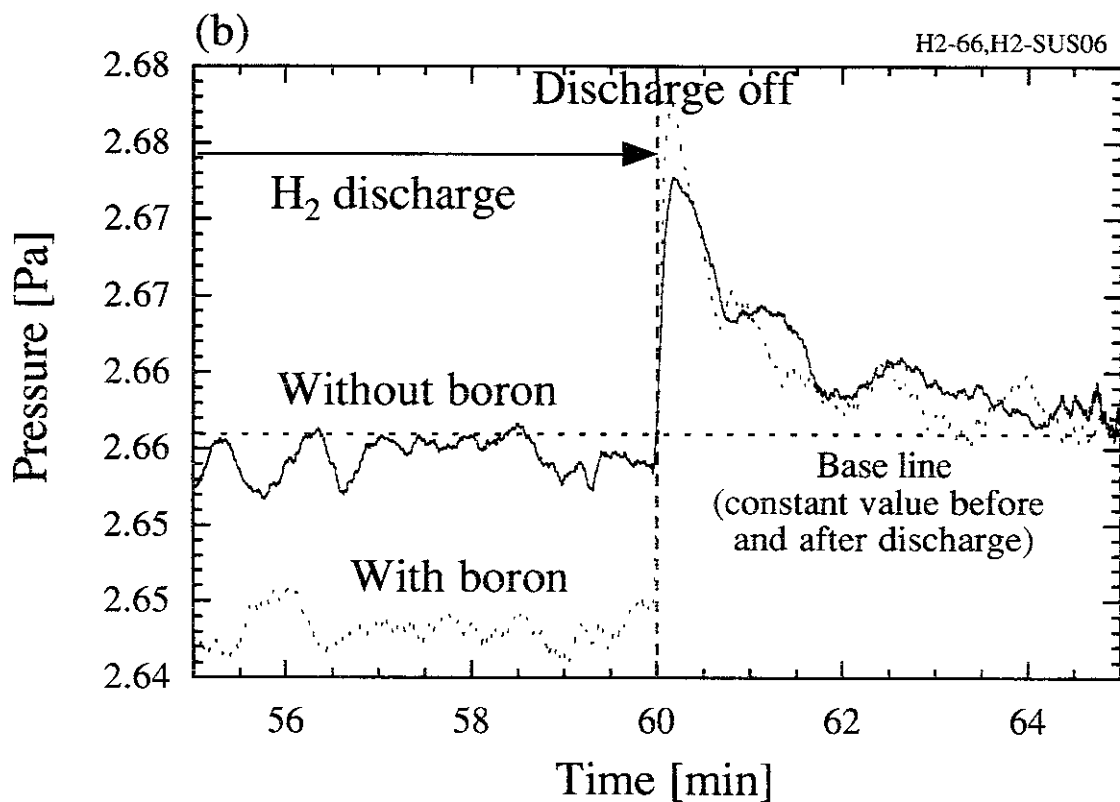
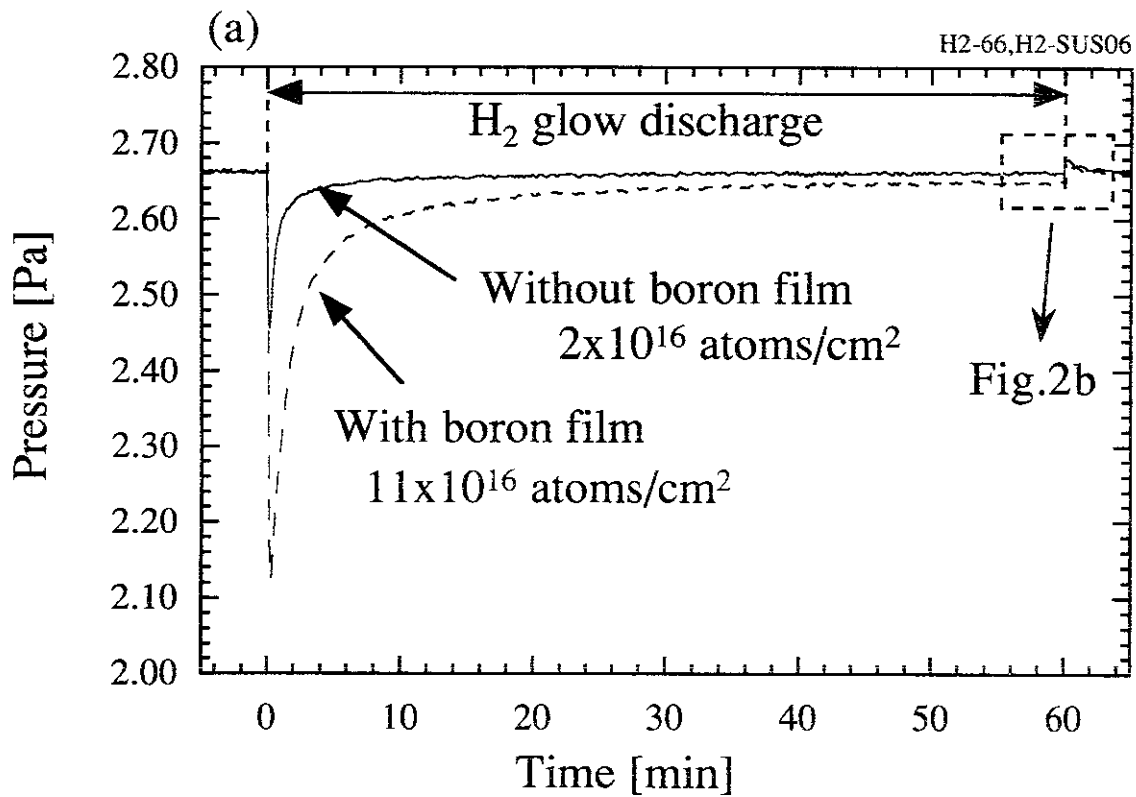

Fig.2. Time evolution of hydrogen pressure during H₂ discharge after H evacuation (stage (I)), with a SS liner with and without B-coating. (a) total discharge time and (b) around the end of discharge are indicated.

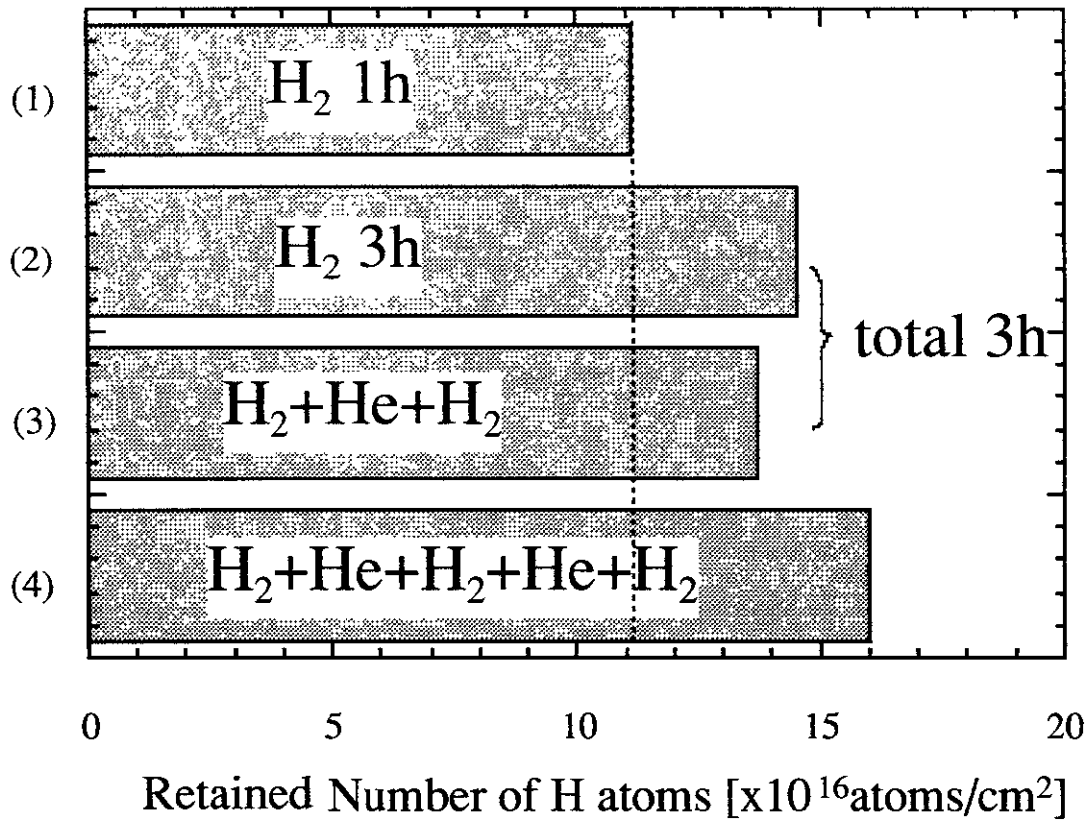

Fig.3. Hydrogen retention in various series of discharge experiments;(a) simple 1 hour H₂ discharge, (b) a longer time discharge (3 hours), (c) Alternate discharge of H₂, He and H₂, (d) Repetition of H₂/He discharges of 5 times.

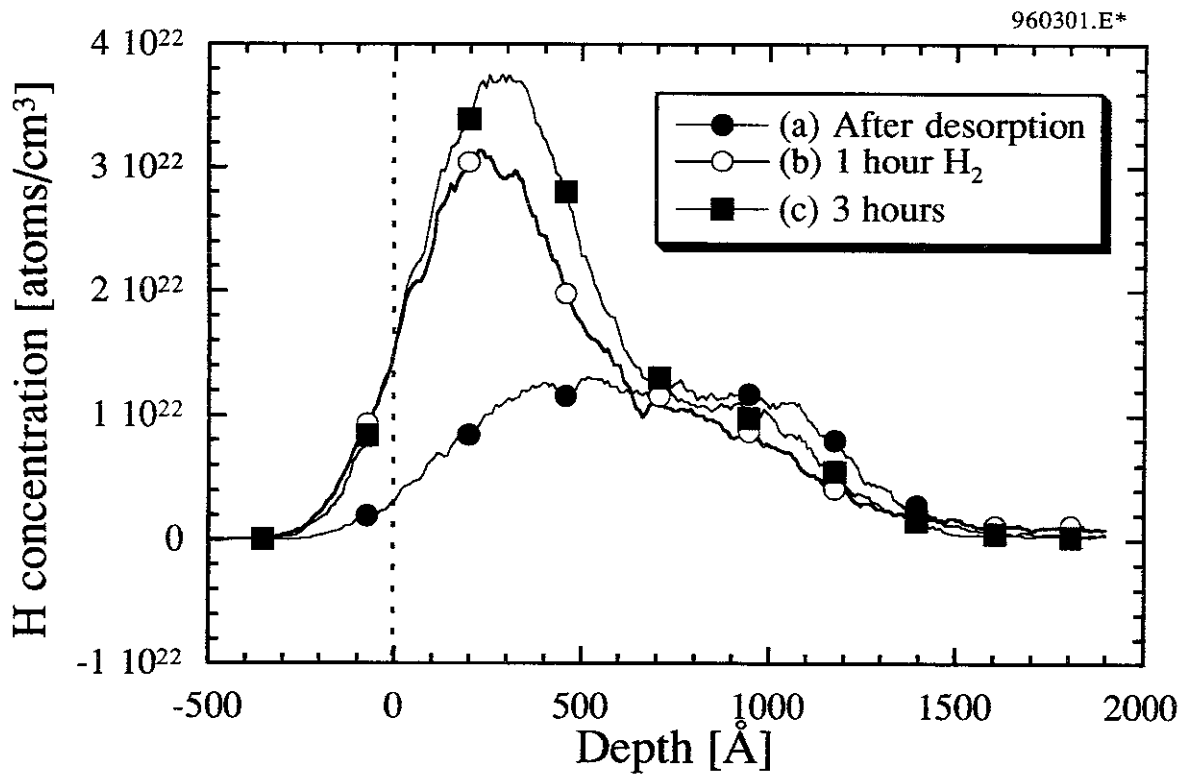

Fig.4. Hydrogen depth profile measured by ERD. The results are indicated for following three samples; (a) just after desorption, (b) 1 hour exposure to H₂ discharge and (c) 3 hours exposure.

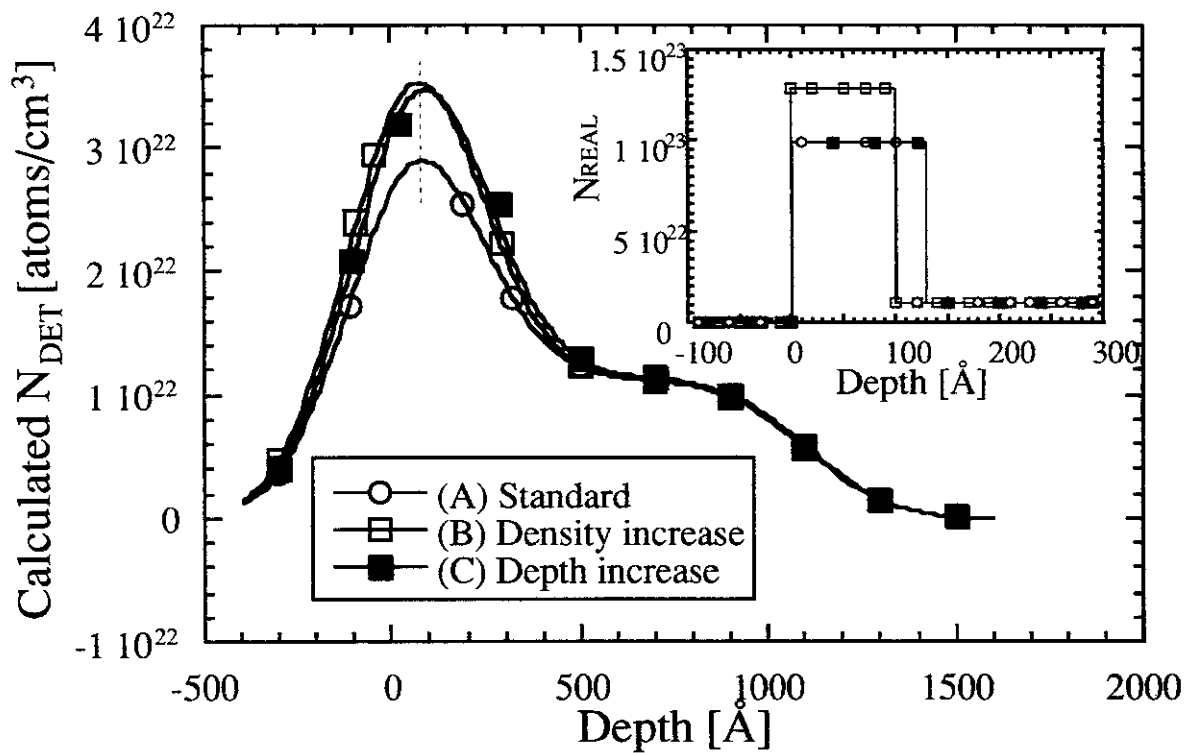

Fig.5. Calculation of detected profile by considering the resolution of ERD. The real profiles of square type are assumed and calculated by taking the convolution with gaussian distribution.

Recent Issues of NIFS Series

- NIFS-386 Y. Katoh, T. Muroga, A. Kohyama, R.E. Stoller, C. Namba and O. Motojima,
Rate Theory Modeling of Defect Evolution under Cascade Damage Conditions: The Influence of Vacancy-type Cascade Remnants and Application to the Defect Production Characterization by Microstructural Analysis; Nov. 1995
- NIFS-387 K. Araki, S. Yanase and J. Mizushima,
Symmetry Breaking by Differential Rotation and Saddle-node Bifurcation of the Thermal Convection in a Spherical Shell; Dec. 1995
- NIFS-388 V.D. Pustovitov,
Control of Pfirsch-Schlüter Current by External Poloidal Magnetic Field in Conventional Stellarators; Dec. 1995
- NIFS-389 K. Akaishi,
On the Outgassing Rate Versus Time Characteristics in the Pump-down of an Unbaked Vacuum System; Dec. 1995
- NIFS-390 K.N. Sato, S. Murakami, N. Nakajima, K. Itoh,
Possibility of Simulation Experiments for Fast Particle Physics in Large Helical Device (LHD); Dec. 1995
- NIFS-391 W.X.Wang, M. Okamoto, N. Nakajima, S. Murakami and N. Ohyaabu,
A Monte Carlo Simulation Model for the Steady-State Plasma in the Scrape-off Layer; Dec. 1995
- NIFS-392 Shao-ping Zhu, R. Horiuchi, T. Sato and The Complexity Simulation Group,
Self-organization Process of a Magnetohydrodynamic Plasma in the Presence of Thermal Conduction; Dec. 1995
- NIFS-393 M. Ozaki, T. Sato, R. Horiuchi and the Complexity Simulation Group
Electromagnetic Instability and Anomalous Resistivity in a Magnetic Neutral Sheet; Dec. 1995
- NIFS-394 K. Itoh, S.-I Itoh, M. Yagi and A. Fukuyama,
Subcritical Excitation of Plasma Turbulence; Jan. 1996
- NIFS-395 H. Sugama and M. Okamoto, W. Horton and M. Wakatani,
Transport Processes and Entropy Production in Toroidal Plasmas with Gyrokinetic Electromagnetic Turbulence; Jan. 1996
- NIFS-396 T. Kato, T. Fujiwara and Y. Hanaoka,
X-ray Spectral Analysis of Yohkoh BCS Data on Sep. 6 1992 Flares - Blue Shift Component and Ion Abundances -; Feb. 1996
- NIFS-397 H. Kuramoto, N. Hiraki, S. Moriyama, K. Toi, K. Sato, K. Narihara, A. Ejiri,

- T. Seki and JIPP T-IIU Group,
Measurement of the Poloidal Magnetic Field Profile with High Time Resolution Zeeman Polarimeter in the JIPP T-IIU Tokamak; Feb. 1996
- NIFS-398 J.F. Wang, T. Amano, Y. Ogawa, N. Inoue,
Simulation of Burning Plasma Dynamics in ITER; Feb. 1996
- NIFS-399 K. Itoh, S-I. Itoh, A. Fukuyama and M. Yagi,
Theory of Self-Sustained Turbulence in Confined Plasmas; Feb. 1996
- NIFS-400 J. Uramoto,
A Detection Method of Negative Pionlike Particles from a H₂ Gas Discharge Plasma; Feb. 1996
- NIFS-401 K.Ida, J.Xu, K.N.Sato, H.Sakakita and JIPP TII-U group,
Fast Charge Exchange Spectroscopy Using a Fabry-Perot Spectrometer in the JIPP TII-U Tokamak; Feb. 1996
- NIFS-402 T. Amano,
Passive Shut-Down of ITER Plasma by Be Evaporation; Feb. 1996
- NIFS-403 K. Orito,
A New Variable Transformation Technique for the Nonlinear Drift Vortex; Feb. 1996
- NIFS-404 T. Oike, K. Kitachi, S. Ohdachi, K. Toi, S. Sakakibara, S. Morita, T. Morisaki, H. Suzuki, S. Okamura, K. Matsuoka and CHS group; *Measurement of Magnetic Field Fluctuations near Plasma Edge with Movable Magnetic Probe Array in the CHS Heliotron/Torsatron*; Mar. 1996
- NIFS-405 S.K. Guharay, K. Tsumori, M. Hamabe, Y. Takeiri, O. Kaneko, T. Kuroda,
Simple Emittance Measurement of H⁻ Beams from a Large Plasma Source; Mar. 1996
- NIFS-406 M. Tanaka and D. Biskamp,
Symmetry-Breaking due to Parallel Electron Motion and Resultant Scaling in Collisionless Magnetic Reconnection; Mar. 1996
- NIFS-407 K. Kitachi, T. Oike, S. Ohdachi, K. Toi, R. Akiyama, A. Ejiri, Y. Hamada, H.Kuramoto, K. Narihara, T. Seki and JIPP T-IIU Group,
Measurement of Magnetic Field Fluctuations within Last Closed Flux Surface with Movable Magnetic Probe Array in the JIPP T-IIU Tokamak; Mar. 1996
- NIFS-408 K. Hirose, S. Saito and Yoshi.H. Ichikawa
Structure of Period-2 Step-1 Accelerator Island in Area Preserving Maps; Mar. 1996
- NIFS-409 G.Y.Yu, M. Okamoto, H. Sanuki, T. Amano,

Effect of Plasma Inertia on Vertical Displacement Instability in Tokamaks;
Mar. 1996

- NIFS-410 T. Yamagishi,
Solution of Initial Value Problem of Gyro-Kinetic Equation; Mar. 1996
- NIFS-411 K. Ida and N. Nakajima,
Comparison of Parallel Viscosity with Neoclassical Theory; Apr. 1996
- NIFS-412 T. Ohkawa and H. Ohkawa,
Cuspher, A Combined Confinement System; Apr. 1996
- NIFS-413 Y. Nomura, Y.H. Ichikawa and A.T. Filippov,
Stochasticity in the Josephson Map; Apr. 1996
- NIFS-414 J. Uramoto,
Production Mechanism of Negative Pionlike Particles in H₂ Gas Discharge Plasma; Apr. 1996
- NIFS-415 A. Fujisawa, H. Iguchi, S. Lee, T.P. Crowley, Y. Hamada, S. Hidekuma, M. Kojima,
Active Trajectory Control for a Heavy Ion Beam Probe on the Compact Helical System; May 1996
- NIFS-416 M. Iwase, K. Ohkubo, S. Kubo and H. Idei
Band Rejection Filter for Measurement of Electron Cyclotron Emission during Electron Cyclotron Heating; May 1996
- NIFS-417 T. Yabe, H. Daido, T. Aoki, E. Matsunaga and K. Arisawa,
Anomalous Crater Formation in Pulsed-Laser-Illuminated Aluminum Slab and Debris Distribution; May 1996
- NIFS-418 J. Uramoto,
Extraction of K⁻ Mesonlike Particles from a D₂ Gas Discharge Plasma in Magnetic Field; May 1996
- NIFS-419 J. Xu, K. Toi, H. Kuramoto, A. Nishizawa, J. Fujita, A. Ejiri, K. Narihara, T. Seki, H. Sakakita, K. Kawahata, K. Ida, K. Adachi, R. Akiyama, Y. Hamada, S. Hirokura, Y. Kawasumi, M. Kojima, I. Nomura, S. Ohdachi, K.N. Sato
Measurement of Internal Magnetic Field with Motional Stark Polarimetry in Current Ramp-Up Experiments of JIPP T-IIU; June 1996
- NIFS-420 Y.N. Nejoh,
Arbitrary Amplitude Ion-acoustic Waves in a Relativistic Electron-beam Plasma System; July 1996
- NIFS-421 K. Kondo, K. Ida, C. Christou, V.Yu.Sergeev, K.V.Khlopenkov, S.Sudo, F. Sano, H. Zushi, T. Mizuuchi, S. Besshou, H. Okada, K. Nagasaki, K. Sakamoto, Y.

- Kurimoto, H. Funaba, T. Hamada, T. Kinoshita, S. Kado, Y. Kanda, T. Okamoto, M. Wakatani and T. Obiki,
Behavior of Pellet Injected Li Ions into Heliotron E Plasmas; July 1996
- NIFS-422 Y. Kondoh, M. Yamaguchi and K. Yokozuka,
Simulations of Toroidal Current Drive without External Magnetic Helicity Injection; July 1996
- NIFS-423 Joong-San Koog,
Development of an Imaging VUV Monochromator in Normal Incidence Region; July 1996
- NIFS-424 K. Orito,
A New Technique Based on the Transformation of Variables for Nonlinear Drift and Rossby Vortices; July 1996
- NIFS-425 A. Fujisawa, H. Iguchi, S. Lee, T.P. Crowley, Y. Hamada, H. Sanuki, K. Itoh, S. Kubo, H. Idei, T. Minami, K. Tanaka, K. Ida, S. Nishimura, S. Hidekuma, M. Kojima, C. Takahashi, S. Okamura and K. Matsuoka,
Direct Observation of Potential Profiles with a 200keV Heavy Ion Beam Probe and Evaluation of Loss Cone Structure in Toroidal Helical Plasmas on the Compact Helical System; July 1996
- NIFS-426 H. Kitauchi, K. Araki and S. Kida,
Flow Structure of Thermal Convection in a Rotating Spherical Shell; July 1996
- NIFS-427 S. Kida and S. Goto,
Lagrangian Direct-interaction Approximation for Homogeneous Isotropic Turbulence; July 1996
- NIFS-428 V.Yu. Sergeev, K.V. Khlopenkov, B.V. Kuteev, S. Sudo, K. Kondo, F. Sano, H. Zushi, H. Okada, S. Besshou, T. Mizuuchi, K. Nagasaki, Y. Kurimoto and T. Obiki,
Recent Experiments on Li Pellet Injection into Heliotron E; Aug. 1996
- NIFS-429 N. Noda, V. Philipps and R. Neu,
A Review of Recent Experiments on W and High Z Materials as Plasma-Facing Components in Magnetic Fusion Devices; Aug. 1996
- NIFS-430 R.L. Tobler, A. Nishimura and J. Yamamoto,
Design-Relevant Mechanical Properties of 316-Type Stainless Steels for Superconducting Magnets; Aug. 1996
- NIFS-431 K. Tsuzuki, M. Natsir, N. Inoue, A. Sagara, N. Noda, O. Motojima, T. Mochizuki, T. Hino and T. Yamashina,
Hydrogen Absorption Behavior into Boron Films by Glow Discharges in Hydrogen and Helium; Aug. 1996