

NATIONAL INSTITUTE FOR FUSION SCIENCE

Innovative Direct Energy Conversion Systems Using Electronic
Adiabatic Processes of Electron Fluid in Solid Conductors:
New Plants of Electrical Power and Hydrogen Gas Resources
without Environmental Pollutions

Y. Kondoh, M. Kondo, K. Shimoda, T. Takahashi, K. Itoh

(Received - June 20, 2001)

NIFS-TECH-11

July 2001

This report was prepared as a preprint of work performed as a collaboration research of the National Institute for Fusion Science (NIFS) of Japan. This document is intended for information only and for future publication in a journal after some rearrangements of its contents.

Inquiries about copyright and reproduction should be addressed to the Research Information Center, National Institute for Fusion Science, Oroshi-cho, Toki-shi, Gifu-ken 509-5292 Japan.

RESEARCH REPORT
NIFS-TECH Series

**Innovative direct energy conversion systems using electronic adiabatic
processes of electron fluid in solid conductors : [†] new plants of electrical power
and hydrogen gas resources without environmental pollutions**

Y. Kondoh, M. Kondo, K. Shimoda, T. Takahashi

Dept. of Electronic Engineering, Gunma University,

Kiryu, Gunma 376-8515, Japan

kondohy@el.gunma-u.ac.jp, <http://www.el.gunma-u.ac.jp/~t-tak/index.html>

[†] Patent application number at the Patent Agency of Japan: 2001-172963

Abstract

It is shown that using a novel recycling process of the environmental thermal energy, innovative permanent auto-working direct energy converter systems (PA-DEC systems) from the environmental thermal to electrical and/or chemical potential (TE/CP) energies, abbreviated as PA-TE/CP-DEC systems, can be used for new auto-working electrical power plants and the plants of the compressible and conveyable hydrogen gas resources at various regions in the whole world, with contributions to the world peace and the economical development in the south part of the world. It is shown that the same physical mechanism by free electrons and electrical potential determined by temperature in conductors, which include semiconductors, leads to the Peltier effect and the Seebeck one. It is experimentally clarified that the long distance separation between two π type elements of the heat absorption (HAS) and the production one (HPS) of the Peltier effect circuit system or between the higher temperature side (HTS) and the lower one (LTS) of the Seebeck effect circuit one does not change in the whole for the both effects. By using present systems, we do not need to use petrified fuels such as coals, oils, and natural gases in order to decrease the greenhouse effect by the CO₂ surrounding the earth. Furthermore, we do not need plants of nuclear fissions that left radiating wastes, i.e., with no environmental pollutions. The PA-TE/CP-DEC systems can be applicable for several km scale systems to the micro ones, such as the plants of the electrical power, the compact transportable hydrogen gas resources, a large heat energy container, which can be settled at far place from thermal energy absorbing area, the refrigerators, the air conditioners, home electrical apparatuses, and further the computer elements. It is shown that the simplest PA-TE/CP-DEC system can be established by using only the Seebeck effect components and the resolving water ones. It is clarified that the externally applied electrical energy is used only for the Joule heating in the total resistance of the circuit, and the transportation of heat energy takes place independently from the external electrical source. It is clarified that since we make the innovative PA-TE/CP-DEC systems in thermally open surroundings, the entropy theory established in the closed system is not applicable for the proposed systems.

Keywords: electronic adiabatic process, electronic heat pumping, free electron fluids in conductors, direct heat-electrical energy conversion system, direct heat-chemical potential energy conversion system, permanent auto-working (PA) electrical power plant, PA plants of hydrogen gas resources, heat recycling systems in open systems

PACS numbers: 89.30.+f, 89.20.+a, 89.90.+n

I. INTRODUCTION

It has been attracted the scientific research that the petrified fuel, such as the oil and the coal, would be consumed out within several tens years from the earth for these several years. The electric power plants using the nuclear fission have inevitable feature of radioactive dust and running without control by careless accidents. On the other hand, the power plants using the nuclear fusion have many advantages compared with the fission plant, such as the low neutron yields to suppress the radioactive dust and naturally shutdown because of cooling of confined plasmas. Various types of confinement system for the fusion plants have been proposed hitherto, such as the Tokamak, Stellarator, Tandem Mirror, Reversed Field Pinches (RFP), Field Reversed Configurations (FRC), Compact Torus (CT), Spherical Tokamak (ST), and so on. In the case of the RFP, the self-organization process has been known to lead to the stable state of the confined plasma. Many theories to interpret the self-organization phenomena in plasmas have been proposed, and one of the authors have been contributed for the development of this research area [1-9]. Since the experimental development of the fusion plant needs a lot of years, we have to develop some other energy resources. On the other hand, research works on the scientific analysis, the application, the industrialization concerning to the Peltier effect and Seebeck one have been published a lot in various journals [10-15].

In this paper, we present innovative direct energy conversion systems using electronic adiabatic processes of electron fluid in solid conductors : new plants of electrical power and hydrogen gas resources, without environmental pollutions. In Section II, we present the theoretical background for the innovative direct energy conversion systems, where Section II-1 is for the Peltier effect and the Seebeck one, Section II-3 is for the electronic heat pumping (EHP), a auto-working EHP system, and new plants of electrical power and the conveyable hydrogen gas resources, without environmental pollutions. We have obtained some experimental evidence such as the conveyable hydrogen gas by a preliminary experiment on the resolving water system. Concluding remarks are in Section IV.

II. THEORETICAL BACKGROUND

We present here a theoretical background for electronic adiabatic processes of free electron fluids in solid conductors which include semiconductors.

II-1. Energy transfers between thermal energies and electrical potential ones of free electrons by electronic adiabatic process

At first, we consider an energy band diagram around contact surfaces among three conductors A, a metal M, and B with external electric field from A side to B one, as schematically shown in Fig. 1.

Here, A and B are conductors with large absolute thermoelectric power, called the (absolute) Seebeck coefficient written as $\alpha_A(T_1)$ and $\beta_B(T_1)$, respectively. The value of the Seebeck coefficient of the metal M such as the copper Cu is usually very small compared with A and B. The Seebeck coefficient depends on the temperature T_1 around contact surfaces. The Fermi energy level is denoted by E_f , the lowest level of the conduction band by E_C , the highest level of the valence band by E_V , and the earth level by E_E . Since the heat conduction is high enough around the two contact surfaces in Fig. 1, the temperature of A, M, and B become respectively the same temperature T_1 as a result. Since the external electric field is applied from A to B, the Fermi level E_f is the highest in A, the middle in M, and the lowest in B. The free electron distribution in conductors can be usually expressed by the Boltzmann distribution. The electrical potential $\phi_A(T_1)$ and $\phi_B(T_1)$ are measured from the E_C level to the E_E one. The potential difference $V_{AB}(T_1)$ between A side and B one is given by

$$V_{AB}(T_1) = \phi_A(T_1) - \phi_B(T_1). \quad (1)$$

We use the two conductors of A and B such that a larger conduction band for A than for B, and therefore the electrical potential has the features of $\phi_A(T_1) > \phi_B(T_1)$. On the other hand, $\phi_A(T_1)$ has the following experimental relation with the use of the relative thermoelectric power (i.e., relative Seebeck coefficient) $\alpha_{AB}(T_1)$, as follows

$$V_{AB}(T_1) = \alpha_{AB}(T_1)T_1 \equiv \alpha_{ABT_1}T_1 > 0, \quad (2)$$

where $\alpha_A(T_1)$ is hereafter abbreviated as α_{ABT_1} , and is written by the Seebeck coefficient $\alpha_A(T_1)$ and $\beta_B(T_1)$ as

$$\alpha_{ABT_1} = \alpha_A(T_1) - \alpha_B(T_1), \quad (3)$$

From Eqs.(1) and (2), we obtain

$$\alpha_{ABT_1} = [\alpha_A(T_1) - \alpha_B(T_1)]/T_1, \quad (4)$$

Every electrons in the free electron fluid in every conductors have their own total energy H written by

$$H = e\phi(T_1) + \frac{m_e}{2}v_{\text{fr}}^2, \quad (5)$$

where $(m_e/2)v_{\text{fr}}^2$ denotes the thermal energy of the every free electrons.

We now consider the electronic adiabatic process of the free electrons in the conduction band around the contact surfaces between A and M, and between M and B, shown in Fig. 1. At first, we pay our attention to every electrons in the free electron fluid. When every free electrons are driven from B to A (the direction of current is inversely from A to B) by external electric fields, they move adiabatic from B to M and M to A through the two contact surfaces, keeping their total energy H , as

follows

$$\begin{aligned}
 H &= e\phi_B(T_1) + \frac{m_e}{2}v_{\text{rB}}^2 \\
 &= e\phi_A(T_1) + \frac{m_e}{2}v_{\text{rA}}^2, \tag{6}
 \end{aligned}$$

where v_{rB} denotes the thermal velocity of every free electrons of interest, which were in B, and v_{rA} is that of the same free electrons which have moved into A. Here, the drift velocity of free electrons by the external electric field can usually be negligible compared with the thermal velocity in the conductors, and therefore the kinetic energy of the free electron by the drift velocity is neglected in Eq.(6). From the electronic adiabatic equation (6), we obtain the followings:

$$\frac{m_e}{2}v_{\text{rB}}^2 - \frac{m_e}{2}v_{\text{rA}}^2 = e[\phi_A(T_1) - \phi_B(T_1)], \tag{7}$$

$$\begin{aligned}
 \frac{m_e}{2}v_{\text{rA}}^2 &= \frac{m_e}{2}v_{\text{rB}}^2 - e[\phi_A(T_1) - \phi_B(T_1)] \\
 &< \frac{m_e}{2}v_{\text{rB}}^2, \tag{8}
 \end{aligned}$$

where $\phi_A(T_1) > \phi_B(T_1)$. From Eq. (7), we can find a physical fact that through the electronic adiabatic process of the free electrons from B to M and from M to A, the thermal energy of the free electrons of interest have been transferred to the electrical potential energy by passing through the two contact surfaces with M. At the same time, we can see from Eq.(8) that the thermal energy of the free electrons of interest has become lower by passing through the contact surfaces. Therefore, the heat absorption takes place in the M side neighbor of the contact surface with B and also in the A side one with M due to the long range Coulomb force interaction among the free electrons, which have flowed in, and those that have existed in A before hand by quite short equi-partition time of thermal energies. When a long cable conductor is attached to the A side, the Coulomb interaction travels along the cable conductor with the speed of electromagnetic waves (EMW). The traveling time of the EMW is greatly shorter due to the light velocity and this time is quite smaller than the equi-partition one due to a lot of interactions among electrons. Equi-partition time between the injected free electrons and positive atoms is the largest one in the A side. If the external electric field to drive free electrons is reversed, the level of E_f in the side of A, M, and B becomes highest in B, middle in M, and lowest in A, and also since free electrons are filled in the conduction band, the level of E_c shifts accordingly, similarly to the level of E_f , i.e., the level of E_c becomes lowest in B, middle in M, and highest in A. Because of these inversed levels, the electrical potential becomes as $\phi_A(T_1) < \phi_B(T_1)$ in Eq. (7). In this case of reversed external electric field, the heat absorption takes place in the M side neighbor of the contact surface with A and also in the B side one with M, consequently. Hereafter, we use a following abbreviate expression for the energy transfer from the

thermal energy to the electrical potential one by the electronic adiabatic process (EAP) of free electron flow through the contact surfaces, as the TE transfer by the EAP. This TE transfer by the EAP in conductors is the fundamental physical mechanism of the well-known Peltier effect elements having the structure of $[A(T_1), M, B(T_1)]$ or simply $[A(T_1), B(T_1)]$. On the other hand, the Seebeck effect elements has the same structure of $[A(T_1), M, B(T_1)]$ or simply $[A(T_1), B(T_1)]$. Since the temperature of conductors becomes higher, the bounded electrons are released more to the free electrons. Therefore, the electrical potential $\phi_A(T_1)$ becomes larger when T_1 is higher. If we keep the temperatures around two contact surfaces for two mutually connected set of Peltier effect elements $[A(T_1), M, B(T_1)]$ or simply $[A(T_1), B(T_1)]$, like as $T_1 > T_2$, then we obtain the series electrical potential difference $V_{cn}(T_1, T_2) = [\phi_A(T_1) - \phi_B(T_1)] + [\phi_B(T_2) - \phi_A(T_2)] = V_{cn}(T_1) + V_{cn}(T_2)$, which is known as induced voltage by the Seebeck effect. We may find from these facts that the Peltier effect and the Seebeck one come from the same physical mechanism embedded in conductors.

II-2. Applications of energy transfers between thermal energies and electrical potential ones by electronic adiabatic process

Using the TE transfer by the EAP, i.e., the Peltier effect, there have been developed the so-called heat pumping modules, which follow the usual gaseous heat pumping with the use of the adiabatic-compression and expansion of circulating gases, are commonly used in various devices such as computers, refrigerators, water coolers, and so on. In the case of the so-called heat pumping modules, the separation between the heat absorption side (HAS) and the heat production one (HPS) are not so large, for example, within a few cm. The separation between the HAS and the HPS should be, however, more variable, so to say, from a few cm to hundreds of km, for more various applications, such as shown in Fig. 2-(a), as a circuit system with the use of the Peltier effect. In the same way, the Seebeck effect circuit system can be established with a large separation between the higher temperature (T_1) side (HTS) and the lower temperature (T_2) one (LTS), as shown in Fig. 2-(b). Here, the labels A and B represent the same materials shown in Fig. 1, but now we use the p type semiconductor for A and the n type one for B. The physical quantities of V_{ex} and I_c are respectively an externally applied DC voltage and the circuit current for the Peltier effect circuit system, V_{out} is the out put voltage induced in the Seebeck effect circuit system, and R_c the total electrical resistance of the cables connecting the both sides of the HAS and the HPS in the Peltier effect circuit or the HTS and LTS in the Seebeck effect one. It is noted here that we use the cables connecting the both sides of the two circuit systems, which are made by conductors being thermally and electrically conductive very well. It should be emphasized here that the long distance separation between the HAS and the HPS or the HTS and the LTS of the two circuit systems does not change any physical mechanisms for the both effects. This is because that since the equi-partition of thermal energies

among the free electrons due to the long range Coulomb force arise within quite short time and the current induced by the external electric field is not carried directly by the free electrons themselves but is flowed by the coupling of electrostatic and electromagnetic forces with the speed of the electromagnetic wave along the cable conductors. Because of these physical mechanisms, the thermal energies at the HAS (so to say positive thermal energy) and at the HPS (i.e., negative thermal energy) in the cables in Fig.2-(a) are cancelled out. In the same way, the induced voltage at the HTS is transferred by the speed of the electromagnetic wave along the cable to the LTS in Fig.2-(b). We also recognize that in the Seebeck effect circuit system, the heat energy is directly converted to the electrical potential energy, as far as the condition of $T_1 < T_2$ is kept in the open systems. This means that the system proposed in Fig. 2-(b) has very high direct energy transfer coefficient from the thermal to the electrical potential energies and gives us freedom to establish easily the electrical power plants with the various separation distances between the HTS area and the LTS one. We do not need the petrified fuels such as coals oils, and also nuclear fission, that left environmental pollutions.

The heat absorption by the Peltier effect in Fig. 2-(a) is written by

$$q_{ABT_1} = \alpha_{ABT_1} T_1 I_c, \quad (9)$$

The circuit and the power balance equations for the circuit in Fig. 2-(a) are written, respectively as follows,

$$I_c (R_1 + R_c + R_2) + \alpha_{ABT_2} T_2 + \alpha_{ABT_1} T_1 = V_{ex}, \quad (10)$$

$$I_c^2 (R_1 + R_c + R_2) + I_c (\alpha_{ABT_2} T_2 + \alpha_{ABT_1} T_1) = I_c V_{ex}, \quad (11)$$

where R_1 and R_2 represent the contact resistances at the HAS and the HPS, respectively. Using Eq.(9), the power balance equation for the heat transportation is written as

$$\alpha_{ABT_1} T_1 I_c = \alpha_{ABT_2} T_2 I_c. \quad (12)$$

Substituting Eq.(12) into Eq.(11), we obtain

$$I_c V_{ex} = I_c^2 (R_1 + R_c + R_2). \quad (13)$$

We clearly notice from Eq.(13) that the externally applied electrical energy is used only for the Joule heating in the total resistance of $(R_1 + R_c + R_2)$, and the transportation of heat energy takes place independently from the external electrical source. This feature of the Peltier effect circuit systems shown in Fig. 2-(a) is remarkable one for development of electronic devices..

The physical mechanism of the heat pumping completely different between the electronic heat pumping (EHP) and the gaseous one (GHP), where the GHP is based on the physical mechanism by

the energy transfer between the gaseous thermal- and the external mechanical energies by the adiabatic compression and expansion of the circulating gases. This different physical mechanism between the EHP and the GHP leads to the followings: 1) The speed of the heat transport is the speed of the electromagnetic wave along the cable conductors in the EHP, while the speed of the heat transport in the GHP is the circulating speed of the working gas in the gas pipe, i.e., heat transfer time is almost negligible in the EHP compared with that in GHP. 2) In the case of the EHP, there is no mechanically moving elements, and Eq.(8) tells us that the heat absorption (or the heat production) always takes place in the conductors as far as the condition of $\phi_A(T_1) > \phi_B(T_1)$ is kept. In other words, the temperatures at A of the HAS and at B of the HPS could have extremely low and high values, respectively, depending on their circumferences. 3) The absorbed thermal energy at the HAS is equal to the transported thermal energy at the HPS, i.e., the conservation of the thermal energy at the HAS and the HPS is automatically guaranteed in the EHP, as discussed at Eq.(13). 4) Since the HAS and the HPS are flexibly separated, for example, the HAS is used for refrigerators or air conditioners, and at the same time, the HPS can be used independently for heating devices such as heating water pots, which can be placed at an arbitrary distance.

Using the system of Fig. 2, we had already done a preliminary experiment by decomposing a set of Peltier elements on the market. At first, applying the external electrical source of $V_{ex} = 5.89$ V, and separating the HAS and the HPS about 1.0 m by a copper wire with $R_C \doteq 1.0 \ \Omega$ and $I_C \doteq 5.89$ A and another nearly 50 m cable one with $R_C \doteq 3.3 \ \Omega$ and $I_C \doteq 1.79$ A, as shown in Fig. 2(a), we had confirmed in the steady state that for the case of 1.0 wire, the HAS was cooled down at $T_1 \doteq 17.2 \text{ }^\circ\text{C}$, the HPS was heated up at $T_2 \doteq 57.7 \text{ }^\circ\text{C}$, and for the case of 50 m cable, the HAS was cooled down at $T_1 \doteq 17.7 \text{ }^\circ\text{C}$, the HPS was heated up at $T_2 \doteq 33.6 \text{ }^\circ\text{C}$. Since I_C becomes down about 30% in the case of 50 m cable compared with that of 1.0 m wire, T_2 comes down about 58 % for the former than the latter. Next, we took off the external source V_{ex} and kept the condition of $T_1 < T_2$, we have confirmed that the induced output voltage becomes about 2.2 mV for the two kinds of wires for Fig. 2(b), and when we make $T_1 > T_2$, then the sign of the output voltage is reversed.

II-3. Permanent auto-working direct heat energy conversion systems from environmental thermal energies to the electrical —and/or chemical potential energy resources

We present here innovative permanent auto-working direct energy converter systems (PA-DEC systems) from the environmental thermal to electrical and/or chemical potential (TE/CP) energy resources. Hereafter we abbreviate this kind of systems as the PA-TE/CP-DEC systems.

At first, we add the Seebeck thermoelectric elements on the heat transfer system of Fig. 2, as shown in Fig. 3. Here, Fig. 3-(a) is the system, where the Seebeck elements are simply added on Fig. 2-(a), and Fig. 3-(b) is the novel system, where we need no initial external electric power source.

In Fig. 3, the thermal energy transportation part is denoted by the mark <1>, and the parts of the DEC with the positive feedback of the Seebeck element output voltage is shown by the mark <2>. The subscript S represents elements concerning with the Seebeck effect. The components of the Seebeck effect are connected in series in order to get the higher out put of the electrical potential difference.

PA-1) Operating sequence of the PA-TE-DEC systems shown in Fig. 3-(a) is as follows: 1) At first, we close the switch 1 and open the switch 2. By this state of circuits, the thermal energy is transported from the HAS to the HPS at the mark <1> to make the temperature T_2 higher and higher. The set of the Seebeck effect elements is contacted to the HPS with the use of the thermally conductive insulator, such as the silicon oil, and the positive feedback driving voltage to the heat transport circuit becomes higher and higher by the Seebeck elements. 2) In order to realize the PA-TE-DEC after the output voltage becomes high enough, we close the switch 2 and open the switch 1, and resultantly the PA-TE-DEC system is established to work without the first external battery.

PA-2) Next, we show the operating sequence of the improved PA-TE-DEC systems shown in Fig. 3-(a): 1) At first, we close the switch 1. 2) Heat the HTS at the mark <2> with the use of some external heater such as fire of woods or a portable heater, so that the temperature T_3 becomes higher and higher. Then, the positive feedback driving voltage by the Seebeck effect elements goes up higher, and the PA-TE-DEC system is established resultantly to work with lesser initial external input energy. The current, I_C , continues to flow by the positive feedback circuit, as far as we keep the condition of $T_3 > T_4$.

The physical reason why we can realize this type of the PA-TE-DEC system is that the present system works in the thermally open system, where the entropy law of thermodynamics in the closed system is not available. We know that the earth itself is one of the open systems, and the thermal energy circulation supports all lives on the earth and also the weather changes every day. Here, the thermal energy changes always its type, such as the electrical energy, the chemical one, the dynamical one, and so on.

Now, we add further a resolving water part as a load for the electrical out put on the system of Fig. 3, as shown in Fig. 4. Here, Fig. 4-(a) is the system, where the a resolving water part is added on Fig. 3-(a), and Fig. 4-(b) is that, where the a resolving water part is added on Fig. 3-(b). Further, we propose the most simple TE/CP-DEC system which has only the Seebeck effect components and the the resolving water part, as shown in Fig. 5. We can see from Figs. 4 and 5 that the electrical potential energy at the Seebeck effect parts is converted to the chemical potential energy as the hydrogen gas and the oxygen one, which are easily compressible and conveyable depending on the porpoise of their usages.

Using hot water flow to keep $T_2 = 76\text{ }^\circ\text{C}$ and a cooling fan to keep $T_3 = 29\text{ }^\circ\text{C}$, we had also done a preliminary experiment on the resolving water system. This experiment corresponds to the case

where we picked up two parts of <3> and <4> in Fig. 4. Using this experimental system with $T_2 - T_3 = 47^\circ\text{C}$, we had obtained H_2 gas of about 5.0 cc and O_2 gas of about 2.5 cc at the pressure of the atmosphere on the earth level after 3 hours.

we can drive motor by burning the hydrogen gas exsorsting just water, or by using the hydrogen fuel battery,. Instead of the resolving water system, we can directly put the storage battery at the part of <4>, which is also conveyable and the chemical potential energy storage system itself, being considered usually the electrical energy storage system for the electrical power supply.

We may find that the present PA-TE/CP-DEC system with the use of the heat recycling system can be used for new plants of electrical power and also hydrogen gas resources without environmental pollutions. Instead of solar battery, we use suitable black materials, so that all energy of the solar light can be absorbed into the black materials. Usual solar battery reflects some part of the solar energy, being lowered its efficiency of the energy conversion.

III. CONCLUDING REMARKS

We have clarified the physical mechanisms for both of the Peltier effect and the Zeebeck one in Section II-1 [cf. from Eq.(1) to Eq.(8)]. We have also clarified that the externally applied electrical energy is used only for the Joule heating in the total resistance of the circuit, and the transportation of heat energy takes place independently from the external electrical source in Section II-2 [cf. from Eq.(9) to Eq.(13)]. We have noted clearly four favorable features from 1) to 4) of the EHP system compared with the GHP at Fig. 2-(a), and have shown that the EHP system can be used for various porpoises. We have clarified that since the HAS and the HPS are flexibly separated, the HAS is used for devices such as refrigerators, air conditioners, and all cooling systems, and at the same time, the HPS can be used independently for heating devices such as heating water pots and all heating water pool systems, which can be placed at any arbitrary distances. We can also propose that using the EHP system, some large heat energy containers can be settled with very long distance from cooling area, where the heat energy can be absorbed from the environment of the area. This means that both of the cooling part and the heating one by the EHP system can be used completely and independently with each other with arbitrary distances. We have also clarified that the long distance separation between the HAS and the HPS in the Peltier effect circuit system and between the HTS and the LTS in the Seebeck effect circuit system does never change any physical mechanisms for the both effects. We have discussed that the Seebeck effect circuit system may have the very high direct energy transfer coefficient from the thermal to the electrical potential energies to make the electrical power plants with the various separations between the HTS area and the LTS one without using such as oils, nuclear fissions, i.e., without environmental pollutions.

In Section II-3, we have clarified that since we are in thermally open surroundings, we can make the auto-working EHP systems in various kind of types. We have shown finally that the present

TE/CP-DEC system using the heat recycling can be used for new plants of electrical power and also hydrogen gas resources without environmental pollutions. It should be emphasized here that the long distance separation between the HAS and the HPS in the Peltier effect circuit system or between the higher and the lower temperature sides in the Seebeck effect circuit system does never change any physical mechanisms for the both effects. We have proposed the most simple PA-TE/CP-DEC system which has only the Seebeck effect component and the the resolving water part (cf. Fig. 5). We must notice here again that the present PA-TE/CP-DEC system does work physically well by the feature of its open system, and the entropy theory established in the closed system is not applicable for the proposed systems. We may expect easily that if the present innovated systems would be used world widely, the green house effect by the CO₂ gas will be decreased and, consequently most of all lives on the earth will be saved through the environmental recovery.

Acknowledgement

The authors would like to appreciate Dr. K. Itoh at Dept. of Electronics, Gunma University, Prof. Momota, University of Illinois, U.S.A., Dr. Y. Tomita, Prof. T. Hayashi, Prof. T. Sato, Dr. S. Yamaguchi, at NIFS, and Prof. S. Shiina at Nihon University, Japan for their valuable comments.

References

- [1] Y. Kondoh: Nucl. Fusion **21** (1981) 1607.
- [2] Y. Kondoh: J. Phys. Soc. Jpn. **54** (1985) 1813.
- [3] Y. Kondoh, T. Yamagishi and M. S. Chu: Nucl. Fusion **27** (1987) 1473.
- [4] Y. Kondoh: J. Phys. Soc. Jpn. **58** (1989) 489.
- [5] Y. Kondoh: Phys. Rev. E **48** (1993) 2975.
- [6] Y. Kondoh: Phys. Rev. E **49** (1994) 5546.
- [7] Y. Kondoh and J. W. Van Dam: Phys. Rev. E **52** (1995) 1721.
- [8] Y. Kondoh, M. Yoshizawa, A. Nakano and T. Yabe: Phys. Rev. E **54** (1996) 3017.
- [9] Y. Kondoh, M. Yamaguchi and K. Yokozuka: J. Phys. Soc. Jpn. **66** (1997) 288.
- [10] T. Harman: J. Appl. Phys. **29** (1958) 1471.
- [11] S. Sherman, R. R. Heikes and R. W. Ure, Jr: "Calculation of Efficiency of Thermoelectric Devices", J. Appl. Phys. **31** (1960) 1.
- [12] R. R. Heikes and R. W. Ure, Jr: "Thermoelectricity: Science and Engineering", New York, Interscience Publishers (1960).
- [13] R. W. Cohen and B. Aueles: J. Appl. Phys. **34** (1963) 1687.
- [14] D.A. Zeskind: Electronics, **53** (1980) 109.

[15] D. M. Rowe and C. M. Bhandari: "Modern Thermoelectrics", London, Holt, Rinehart and Winston (1983).

Fig.1. Schematic drawing of energy band diagram around a contact surface between two conductors A and B. Here, the Fermi energy level V_f in the conduction band of the two conductors is in the same level, the potential $\phi(T_1)$ is measured from the Fermi level to each conductor surface, T_1 is the temperature, and $\phi_A(T_1) > \phi_B(T_1)$ is assumed.

Fig. 2. The Peltier effect element circuit system and the Seebeck effect element circuit system. Here, Fig. 2-(a) is the electronic heat pumping system by the Peltier effect element with the flexible separation between the heat absorption side (HAS) and the heat production one (HPS) from a few cm to thousands of km, for more various applications. Here, the labels A and B represent the same materials shown in Fig. 1, V_{ex} is an externally applied DC voltage, I_c the circuit current, R_c the total electrical resistance of the cables connecting the two side of the HAS and the HPS, and T_1 and T_2 denote the temperatures at the HAS and the HPS, respectively.

Fig. 2-(b). is the Seebeck effect circuit system with the large flexible separation between the higher temperature (T_1) side and the lower temperature (T_2) one.

Fig.3. Auto-working systems by adding the Seebeck thermoelectric element on the heat transfer system of Fig. 2-(a). Here, Fig. 3-(a) is the system, where the Seebeck element is simply added on Fig. 2-(a), and Fig. 3-(b) is the novel system, where we need no external electric power source. In the figure, the HAS is denoted by the mark <1>, the HPS is by the mark <2>, and the Seebeck element part is by the mark <3>. The subscript S represents elements concerning with the Seebeck effect. Many components of the Seebeck effect are connected in series in order to get the higher output of the electrical potential difference.

Fig.4. A novel auto-working plant system by adding a resolving water part as a load for the electrical output on the system of Fig. 3. Here, Fig. 4-(a) is the system, where the a resolving water part is added on Fig. 3-(a), and Fig. 4-(b) is that, where the a resolving water system added on Fig. 3-(b).

Fig.5. The most simple TE/CP-DEC system which has only the Seebeck effect components and the resolving water part.

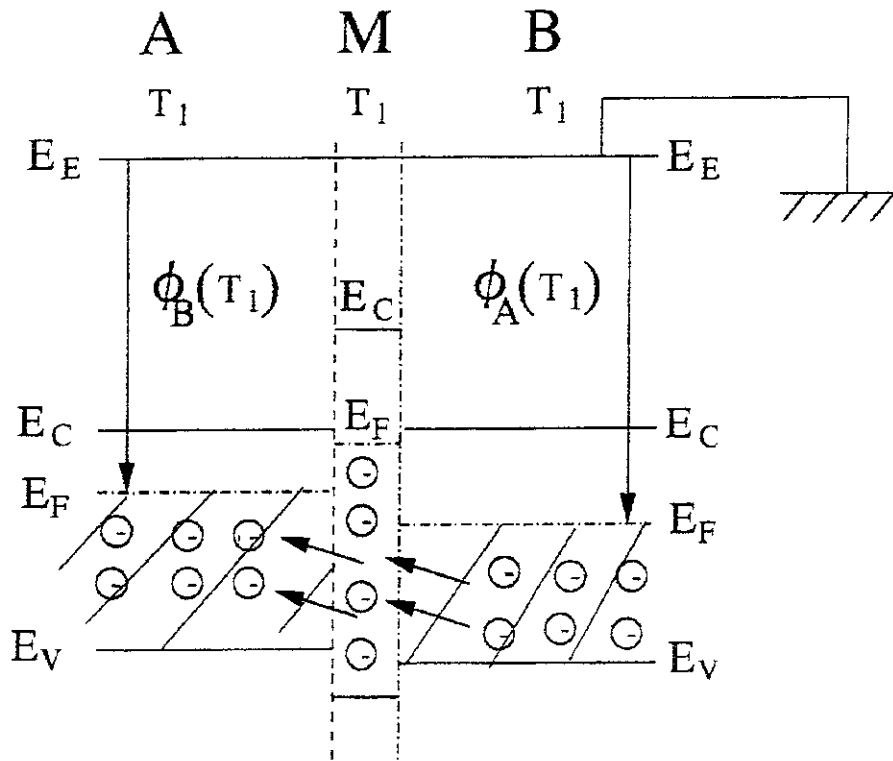

Fig. 1

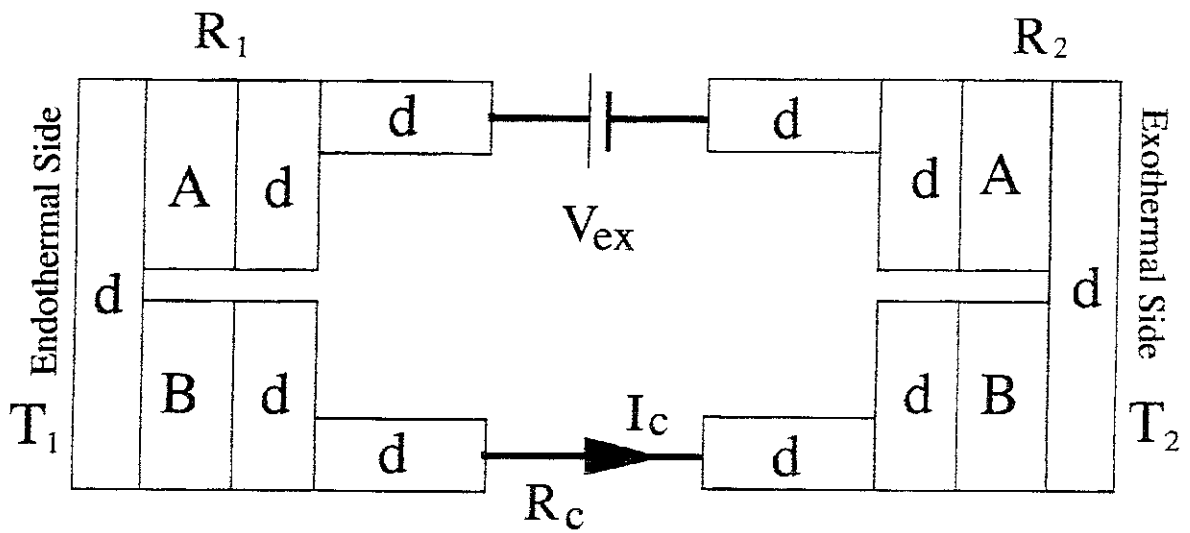

Fig. 2-(a)

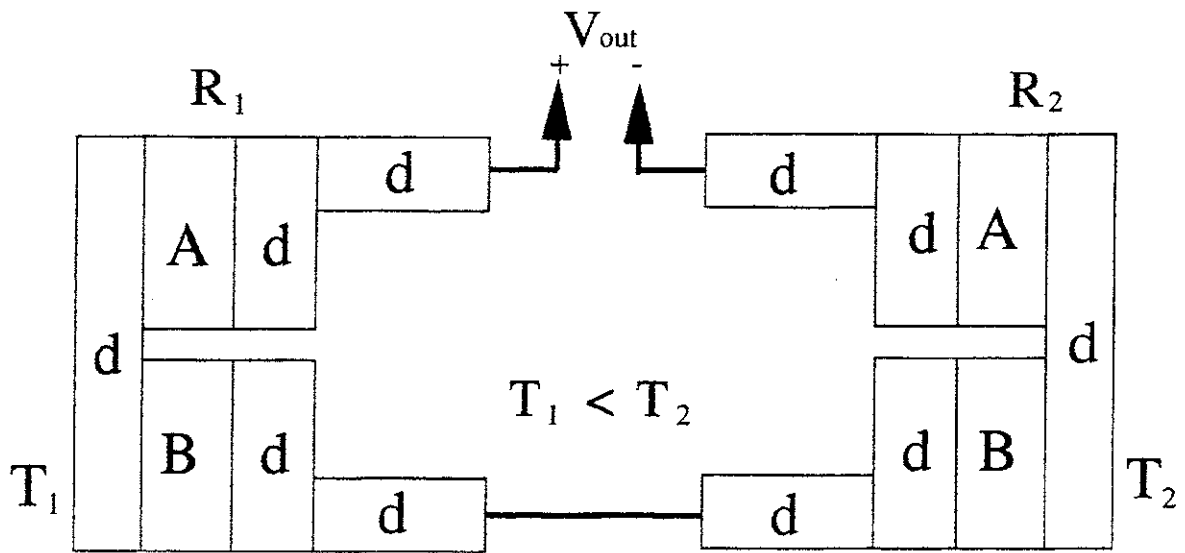

Fig. 2-(b)

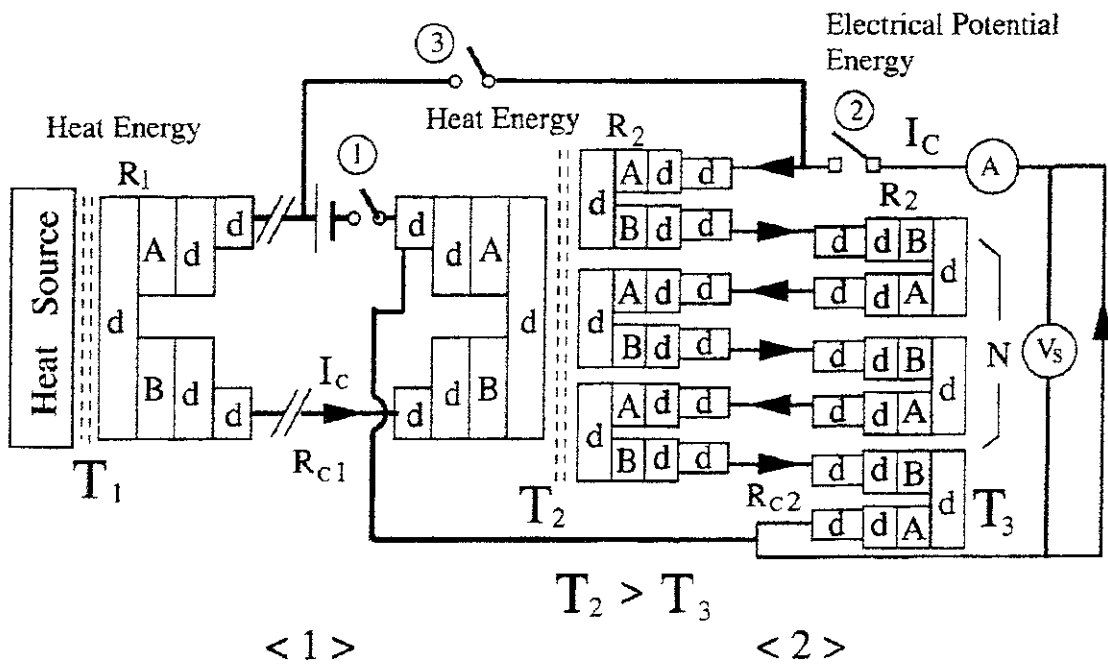
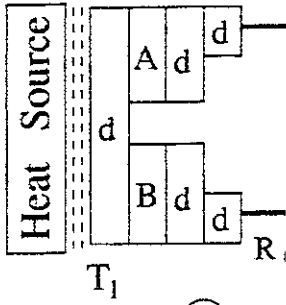

Fig. 3-(a)

Thermal Energy



1. swich (1) on
2. Heat [2] on
3. If $T_2 \sim T_3$ th

<

Thermal Energy

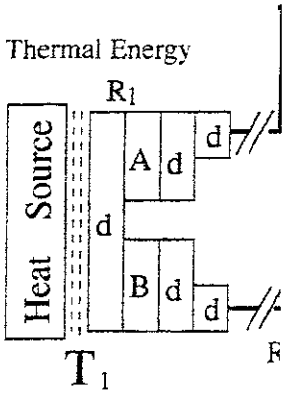

<

Publication List of NIFS-TECH Series

- NIFS-TECH-1 H. Bolt and A. Miyahara,
Runaway-Electron -Materials Interaction Studies ; Mar. 1990
- NIFS-TECH-2 S. Tanahashi and S. Yamada,
Dynamic Analysis of Compact Helical System Power Supply and Designs of Its Upgrade: Sep. 1991
- NIFS-TECH-3 J. Fujita, K. Kawabata, S. Okajima, A. Mase, T. Suzuki, R. Kuwano, K. Mizuno, T. Nozokido, J.J.Chang and C.M.Mann,
Development of High Performance Schottky Barrier Diode and its Application to Plasma Diagnostics;
Oct. 1993 (in Japanese)
- NIFS-TECH-4 K.V. Khlopenkov, S. Sudo, V.Yu. Sergeev,
Operation of the Lithium Pellet Injector: May 1996
- NIFS-TECH-5 Nakanishi, H., Kojima, M. and Hidekuma, S.,
Distributed Processing and Network of Data Acquisition and Diagnostics Control for Large Helical Device (LHD); Nov. 1997
- NIFS-TECH-6 Kojima, M., Nakanishi, H. and Hidekuma, S.,
Object-Oriented Design for LHD Data Acquisition Using Client-Server Model; Nov. 1997
- NIFS-TECH-7 B.N. Wan, M. Goto and S. Morita,
Analysis of Visible Spectral Lines in LHD Helium Discharge: June 1999
- NIFS-TECH-8 Y. Zhao, Y. Torii, T. Mutoh, R. Kumazawa, F. Shimpo, T. Seki, K. Saito, G. Nomura and T. Watari,
ICRF Waveform Controlling; Dec. 1999
- NIFS-TECH-9 H. Nakanishi, M. Kojima, M. Ohsuna, S. Komada, M. Emoto, H. Sugisaki, S. Sudo and LABCOM group,
Distributed Mass Data Acquisition System Based on PCs and Windows NT for LHD Fusion Plasma Experiment: Dec. 2000
- NIFS-TECH-10 H. Nakanishi, M. Kojima and LABCOM Group,
Design for Real-Time Data Acquisition Based on Streaming Technology: Apr. 2001
- NIFS-TECH-11 Y. Kondoh, M. Kondo, K. Shimoda, T. Takahashi, K. Itoh,
Innovative Direct Energy Conversion Systems Using Electronic Adiabatic Processes of Electron Fluid in Solid Conductors:
New Plants of Electrical Power and Hydrogen Gas Resources without Environmental Pollutions; July 2001