

## §2. Measurement of Edge Plasma Fluctuation by 2-D Thermal Li Beam

Ohno, N., Takamura, S. (Nagoya Univ.),  
Morisaki, T., Masuzaki, S., Komori, A.

Non-diffusive transport phenomenon that plasma blobs transport across lines of magnetic force becomes an important research topic in the edge plasmas of fusion devices. The development of two dimensional measurement of density fluctuation in scrape-off layer (SOL) regions is important to clarify the propagation mechanism of plasma blobs. The density measurement by using the thermal lithium beam has been done in NIFS to reveal important edge phenomena[1]. Two dimensional thermal lithium beam source was developed to obtain two dimensional density distribution in the SOL of LHD[2].

In order to verify validity of two dimensional measurement of density fluctuation in the SOL by using two dimensional thermal lithium beam, it is necessary to improve reconstruction algorithm to reduce artificial effects of fluctuation propagation associated with lithium beam propagation. Moreover, detailed comparative study with the fluctuation measurement by probe should be required.

In this study, it has aimed to develop two dimensional density fluctuation measurements by using thermal lithium beam in cooperation with Nagoya University and NIFS.

The problem in the present thermal lithium beam source was intensively discussed, and the points that had to be improved were clarified. Especially, we concluded that a decrease of pollution by the lithium dispersion in the vacuum chamber and improvement of heating characteristic of the lithium oven are urgent issues.

Tungsten heater decided to be introduced in the

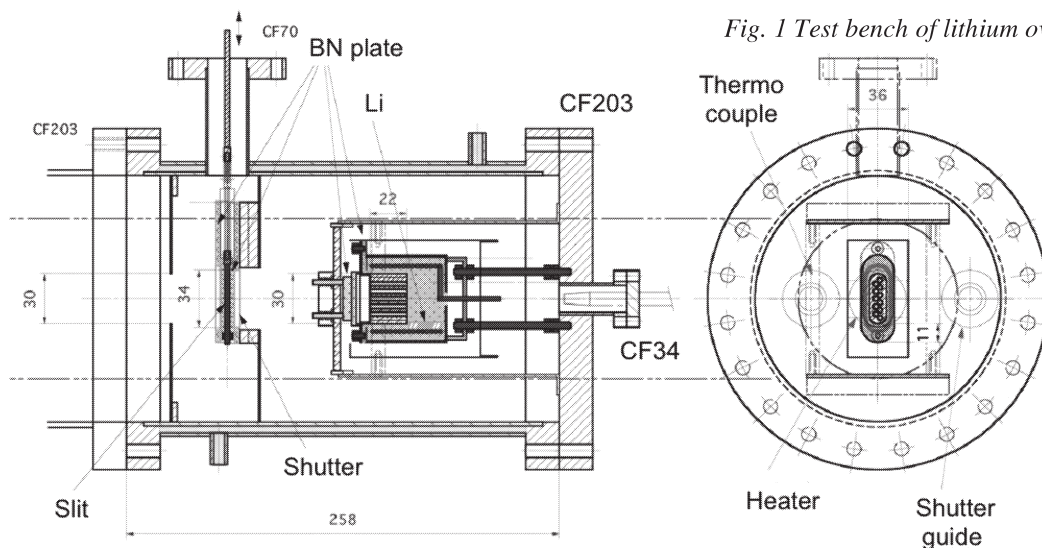

Fig. 2 Design of lithium beam oven

lithium oven for the improvement of the heating characteristic, and to use boron nitride (BN) as an insulating material. However, there was no chemical data concerning the chemical reaction under the high temperature of the lithium, tungsten, and the BN materials. In order to test the interaction between these materials, the oven for the test of the heatproof material was produced (Fig. 1). As a result, it was clarified to be able to use the above-mentioned heatproof material for the lithium beam source. It should be noted that the oven for the test was developed under the strong support by the engineering department of NIFS.

The lithium beam source of Fig. 2 was designed based on the above-mentioned findings. The feature is high temperature of lithium oven due to tungsten heater introduction and well-sealed mechanical shutter made of BN material. Moreover, a horizontal setting of the lithium oven is possible. It is scheduled to do two dimensional measurements of a small tokamak by using the developed lithium beam source in 2007 fiscal year.

### References

- 1) T. Morisaki *et. al.*, Plasma. Phys. Control. Fusion, **37**, 787 (1995).
- 2) Y. Takahashi *et. al.*, Plasma and Fusion Research, **1**, 013 (2006).

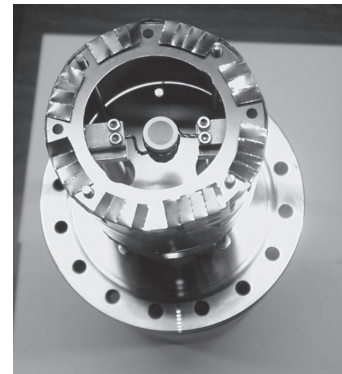

Fig. 1 Test bench of lithium oven