

§5. Measurement of Electron Bernstein Wave Emission from Ultra High Beta Plasmas

Ono, Y., Ito, S. (Graduate School of Frontier Sciences, Univ. Tokyo), Kawamori, E. (National Cheng Kung Univ.), Igami, H.

Electron Bernstein wave (EBW) has been used to overcome a density limit by which accessibility of conventional electron cyclotron resonance heating is limited. In order to apply EBW to heating of an ultra high-beta (volume average beta $\geq 80\%$) plasma, we developed a diagnostic system of electron Bernstein wave emission (EBE) for compact torus experiments, which is an inverse process of mode conversion of EBW heating.

Figure 1 shows a schematic of the EBE measurement system which we had developed for TS-4 field reversed configuration (FRC) plasmas at University of Tokyo (Magnetic field ~ 0.01 T, electron density \sim the order of 10^{20} m^{-3} , $\omega_{pe}/\omega_{ce} \geq 100$). The frequency measured by our system is resonant with the sixth or seventh electron cyclotron layer near the plasma edge. The electromagnetic wave emitted from the FRC plasmas is detected by a waveguide antenna and is transmitted to a detector module through a waveguide-coaxial cable converter, coaxial cable, attenuators and amplifiers. The detector module surrounded by a bold line frame in Fig. 1, was fabricated using microwave integrated circuit (MIC) technology by Kyushu University group [1]. Adoption of the MIC technique contributes to downsizing and cost-reduction of the system. Each channel of the measurement system covers frequency range of 2-5.1 GHz with bandwidth of 500 MHz.

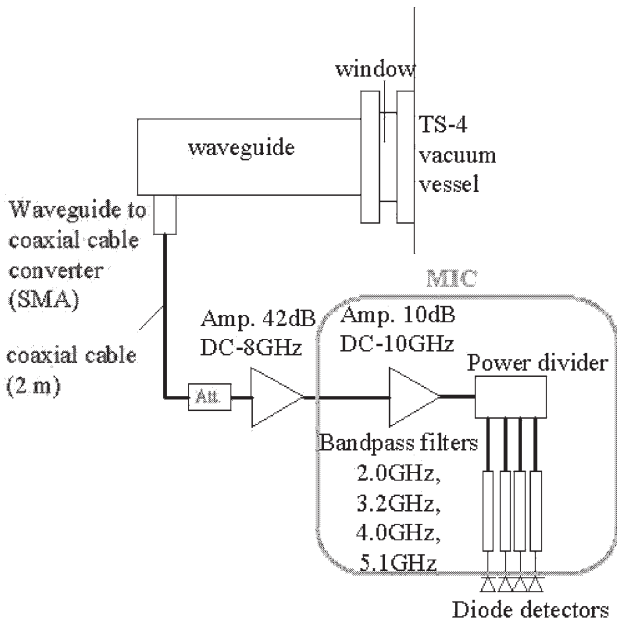

Fig. 1. Schematic of the EBE measurement system. The microwave integrated circuit (MIC) technology was utilized for the detector module.

The EBE signal measured in the TS-4 FRC plasma experiments after installation of the system, did not reach significant signal level. We carried out a bench test of the system to confirm sensitivity and linearity of the detection system to the expected radiation power from the FRC plasma. A signal generated by an oscillator was transferred to the detector through the amplifier, an attenuator and a band pass filter. Output voltage of the detector is plotted as a function of the input power in Fig. 2. It was found that the system has sufficient sensitivity for the input power of -70 dBm which is an EBE radiation power in thermal equilibrium state estimated under the condition of electron temperature of 1 eV, conversion efficiency from EBW to electromagnetic mode of 10 % and bandwidth of 1 GHz. Figure 2 also indicates good linearity of output voltage to the input power in the range from -100 to -60 dBm.

We will upgrade this system and reinstall it to another compact torus device TS-3 to obtain better accessibility to a plasma and flexibility of configuration of the measurement such as receiving angle of EBE radiation. The new design enables us to experimentally determine optimal angle of the mode conversion from EBW to electromagnetic wave. Since the density gradient at edge of TS-3 FRC is considered to be sufficiently steep at the location of the UHR layer, the UHR layer will be close to the right-hand cutoff. Finally, some of the power trapped in the plasma can tunnel through to electromagnetic, X-mode branch, in agreement with the mode conversion process we expect.

[1] Y. Kogi, et al., "Development of IF system for ECE radiometer on KSTAR tokamak", in Proceedings of the 13th International Symposium on LASER-AIDED PLASMA DIAGNOSTICS, 18-21 September, 2007 Hida Hotel Plaza, Takayama, Japan (NIFS-Proc-68)

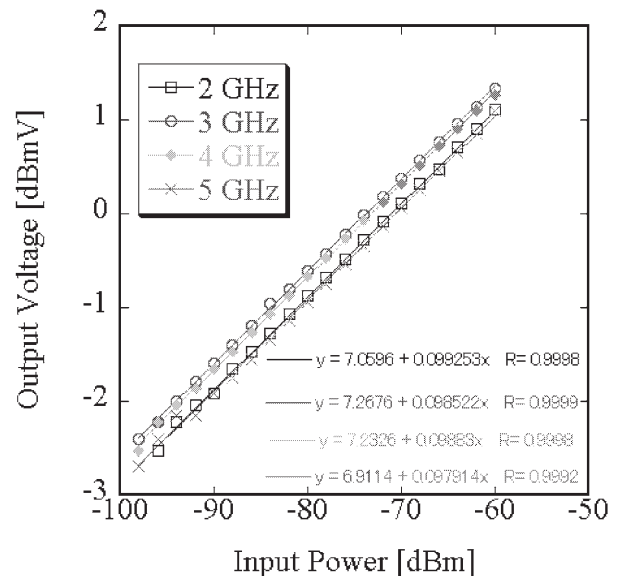

Fig. 2. Relation between input power and output voltage of the EBE detection system.