

## §19. Optics System Design for Microwave Imaging Reflectometry in LHD

Yoshinaga, T., Nagayama, Y., Tsuchiya, H., Kuwahara, D., Tsuji-Iio, S. (Tokyo Tech.), Yamaguchi, S. (Kansai Univ.), Kogi, Y. (Fukuoka Institute of Technology), Hojo, H. (Univ. Tsukuba), Mase, A. (Kyushu Univ.)

Microwave Imaging Reflectometry (MIR) has been developed in NIFS to study transports and instabilities in the helical plasmas in Large Helical Device (LHD). MIR is a multi-receiver reflectometry diagnostics and it can potentially reconstruct three-dimensional structures of electron density fluctuations in fluctuating plasmas. The MIR system installed in LHD receives the scattered microwaves at four different frequencies with the two-dimensionally arranged (toroidally  $5 \times$  poloidally 7 channels) horn-antenna mixer array (HMA), which consists of the arrayed quasi-optical antenna-mixers covered with the pyramidal horn apertures [1]. The received microwave signal is down-converted into the intermediate frequency (IF) signals inside each HMA aperture by mixing the scattered signal wave with the local oscillator (LO) wave, which also cast onto the HMA aperture from the front-side.

In 2009 the optics system, which consists of the curved mirrors of aluminum-alloy (I1, I2, R1, R2 and L1) and the dielectric beam splitters (BS1-3), was optimized for this HMA. The system layout is illustrated in Fig. 1. This system is required to realize the following three functions with some common mirrors. 1) The illuminating probe wave is projected into the plasma in a parallel beam shape. The beam width should be as wide as the observing area of the HMA. 2) The scattered signal wave from the cutoff surface is focused on the HMA aperture. 3) The LO beam is casted to cover the HMA aperture to supply LO signal at an enough power level to operate the down-conversion mixer (Shottky diodes). The ellipsoidal or hyperboloidal shapes of the mirrors are determined for the above-mentioned requirements. The 2-D finite-difference time-domain (FDTD) method is used to simulate the beam shapes. Since FDTD method directly computes the Maxwell equations, the effect of finite wavelength ( $\lambda = 5$  mm at  $f = 60$  GHz) is intrinsically simulated. The designed beam patterns of 1) the illuminating wave, 2) the scattered wave and 3) the LO wave is shown in Figs. 2 (a)-(c), respectively. The simulated beam patterns seem to satisfy the requirements.

For verifying the performance of the constructed optics system the LO beam intensity distribution on the HMA aperture surface is measured and compared with the designed one as shown in Fig. 3. The measured profile of the LO beam (filled and open circle) is found to agree with the calculated profile (dashed line). Especially the measured beam intensity is roughly constant in the HMA aperture area from -50 mm to 50 mm. Moreover, it is confirmed that the LO wave beam with a circular cross section covers the HMA aperture with a rectangle of 100

mm  $\times$  100 mm. These results show that the LO power is ideally supplied to every channels of HMA in a similar power level. The signal level of the present MIR system became higher compared with the previous experimental cycle, resulting in the clear FFT spectra of the MHD activities in the edge plasma region [1]. This shows that the present optics is better matched to the 2-D HMA. To improve the performance of the present MIR system it is planned to tilt the vacuum window to avoid the excitation of the interfering standing wave.

[1] Nagayama, Y. *et al.*, in this Annual Report.

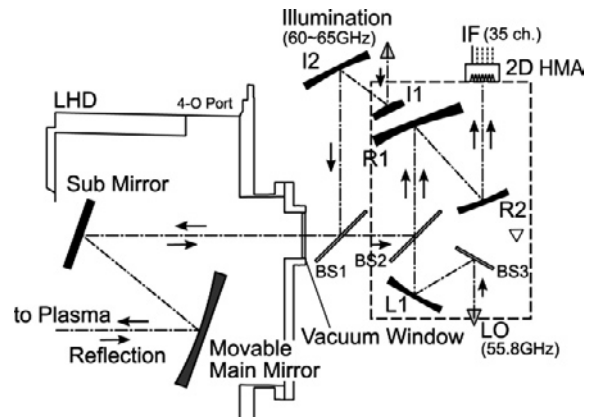

Fig. 1. MIR optics system in LHD.

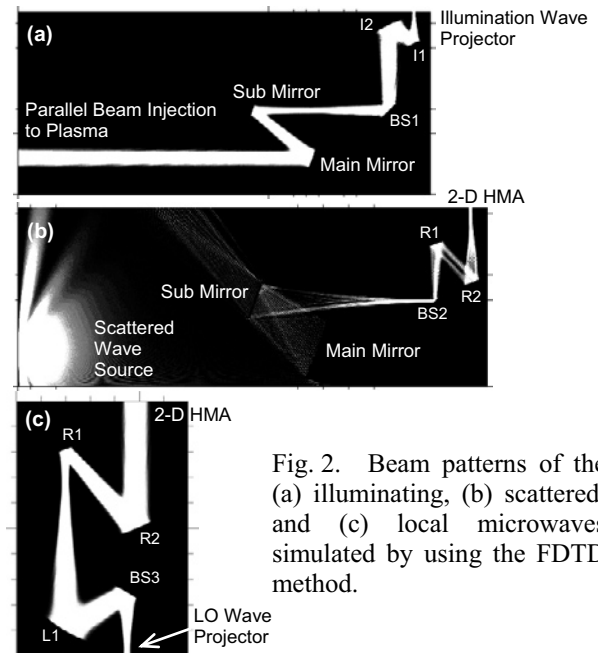

Fig. 2. Beam patterns of the (a) illuminating, (b) scattered, and (c) local microwaves simulated by using the FDTD method.

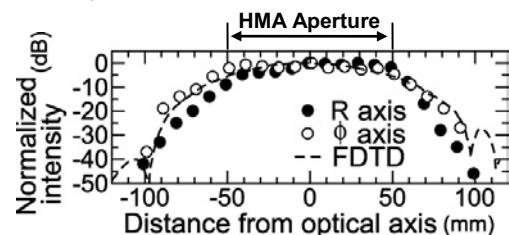

Fig. 3. LO-beam intensity profile at HMA aperture.